

# easicook.co.uk

## Spare Parts Manual

Leading UK Distributors  
of Catering Equipment Since 1977

Sales - Repairs - Spares

Tel: 029 20747567

Fax: 029 20214100

Email: [info@easicook.co.uk](mailto:info@easicook.co.uk)

---

# DISHWASHER

ELECTROMECHANICAL SWITCHES  
LOWER AND UPPER WASHING

TYPE: 29P

Accessories  
BREAK TANK  
BOOSTER PUMP  
DVGW  
COLD RINSE  
WATER SOFTNER  
DETERGENT DISPENSER  
DRAIN PUMP

---

## Spare parts manual

---

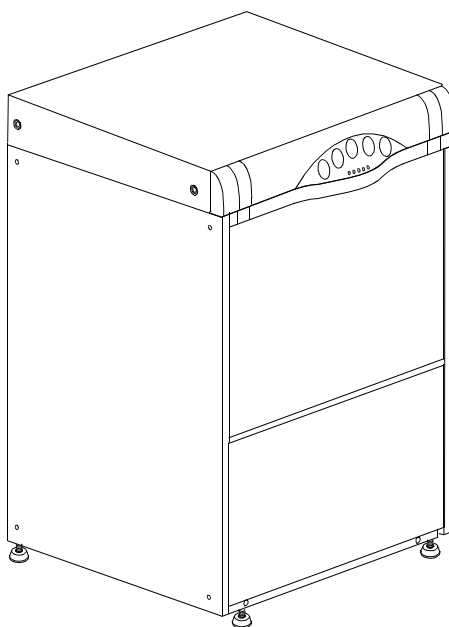



## 1. Spare parts

General body parts.....	7
Lockup system .....	9
Control panel .....	11
Control electric components.....	13
Solenoid valve group .....	15
Solenoid valve group .....	17
Break Tank .....	19
Booster pump.....	21
DVGW .....	23
Water softner group.....	25
Shining product dosing device group .	27
Shining product dosing device group .	29
Boiler group .....	31
3 ways derivation.....	33
Wash pump .....	35
Dosing device group .....	37

---

<b>Dosing device group .....</b>	<b>39</b>
<b>Drain pump group.....</b>	<b>41</b>
<b>Pressure switch group with air trap ...</b>	<b>43</b>
<b>Turret group with rotating arms .....</b>	<b>45</b>

## 1.1 Voltage codes

Voltage code	Voltage
A	3/N/PE~400/230V 50Hz
B	~250V 16A 50Hz
C	3/N/PE~380/220V 50Hz
D	3/PE~200V 50-60Hz
F	2/PE 220-240V 50Hz
G	3/N/PE~415/240V 50Hz
H	3/PE~230V 50Hz
I	3/PE~220V 60Hz
J	3/PE~380 50Hz
K	3/PE~400V 50Hz
L	3/PE~415V 50Hz
M	3/PE~440V 60Hz
N	3/PE~460V 60Hz
O	3/PE~480V 60Hz
P	1/N/PE~220-240V 50Hz
R	2/PE~220-230V 60Hz
S	3/N/PE~400/230V 50Hz
T	3/PE~230V 60Hz

## 1.2 Product codes

Product code	Full name
Model codes	
em	ELECTROMECHANICAL SWITCHES
ls	LOWER AND UPPER WASHING
Type codes	
29P	29P
Accessory codes	
bt	BREAK TANK
pap	BOOSTER PUMP
dvgw	DVGW
fs	COLD RINSE
d	WATER SOFTNER
dde	DETERGENT DISPENSER
ps	DRAIN PUMP

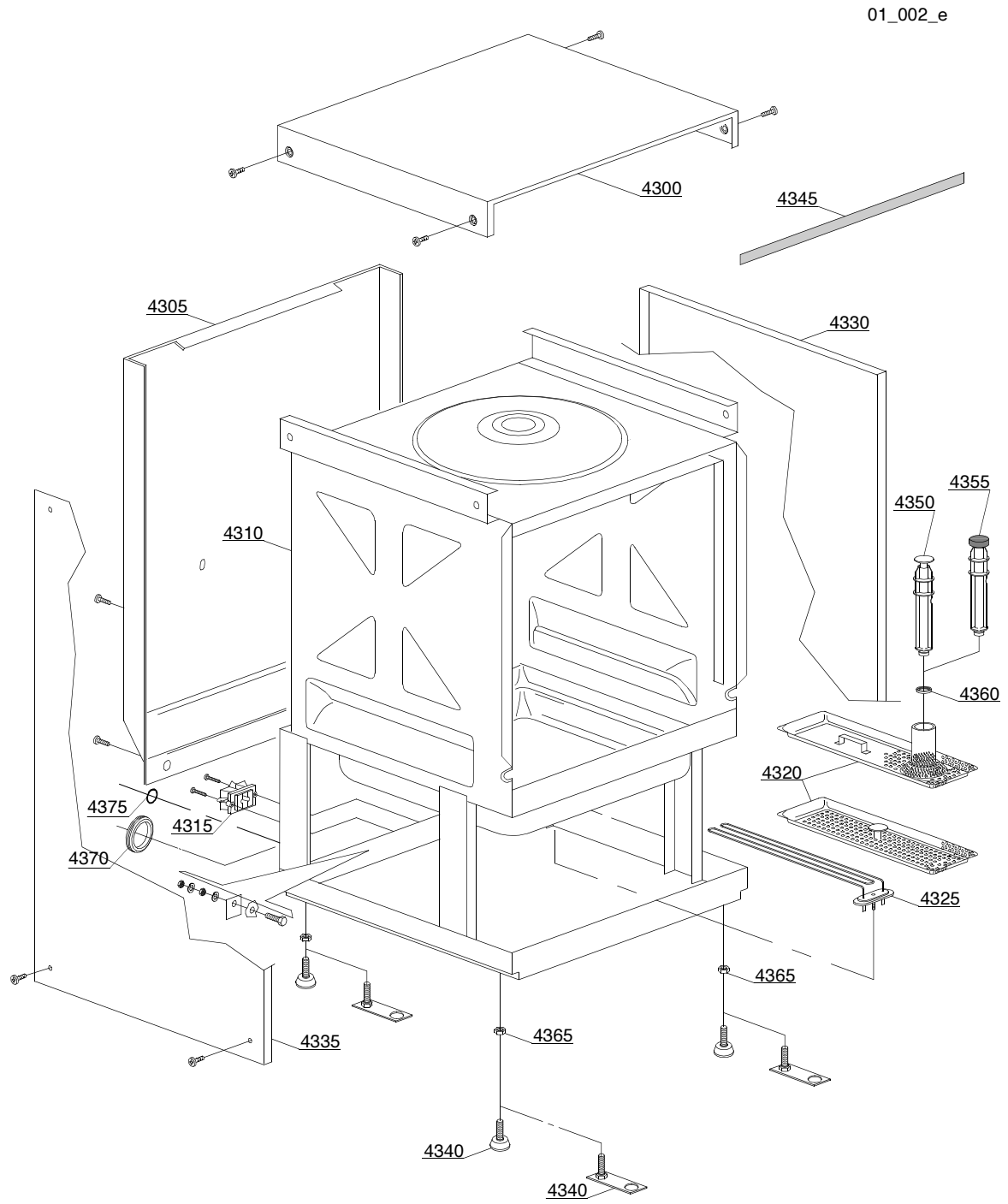





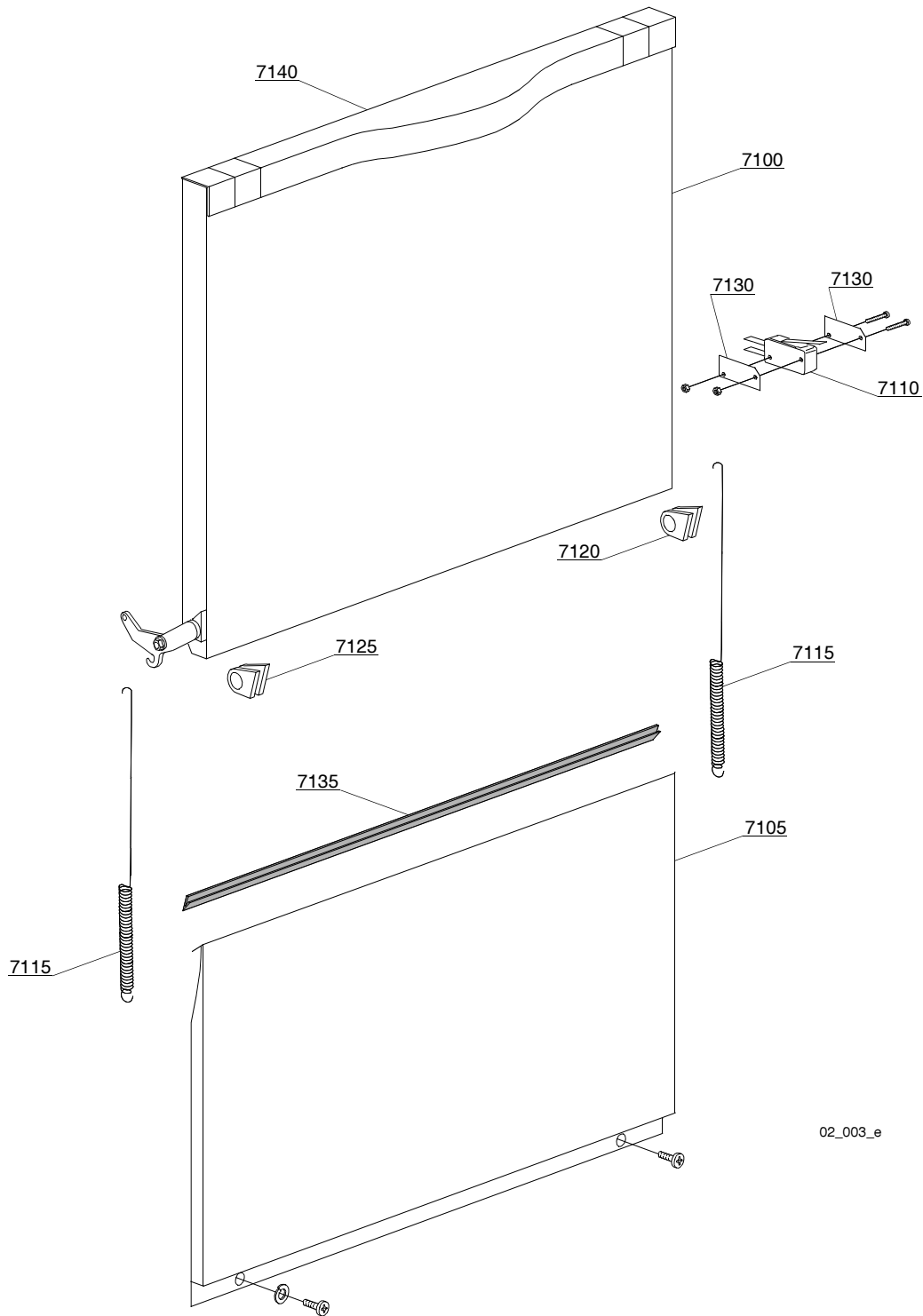

02\_003\_e



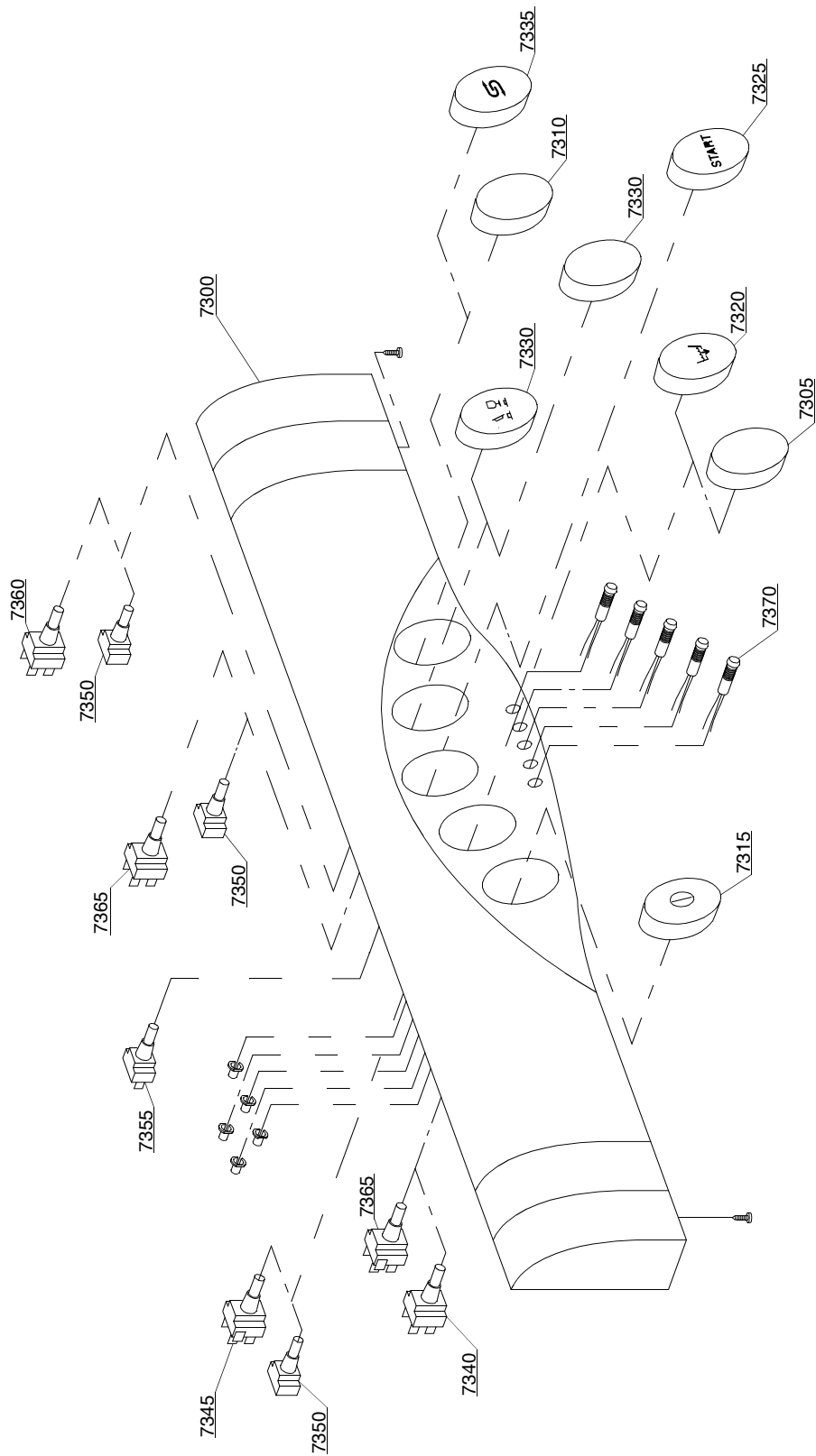

03\_102\_e

## Spare parts

ID	P-code	Model	Type	Accessory	Voltage	Description
MODULE:Control panel						
7300	560501		29P			Control panel
7305	560523/A		29P			Key 2 with point
7310	560526/A		29P			Key 5 with point
7315	560527/A		29P			ON-OFF key 1
7320	560528/A		29P			Drain pump key 2
7325	560529/A		29P			Start key 3
7330	560530/A		29P			Selector switch key 4
7335	560531/A		29P			Regeneration key 5
7340	15811		29P			16A bipolar switch
7345	15811/A		29P			16A bipolar switch push button
7350	15844		29P			Key support
7355	15813		29P			16A unipolar push button
7360	15800		29P			16A bipolar push button
7365	15812		29P			16A switch
7370	10711		29P			Pilot light

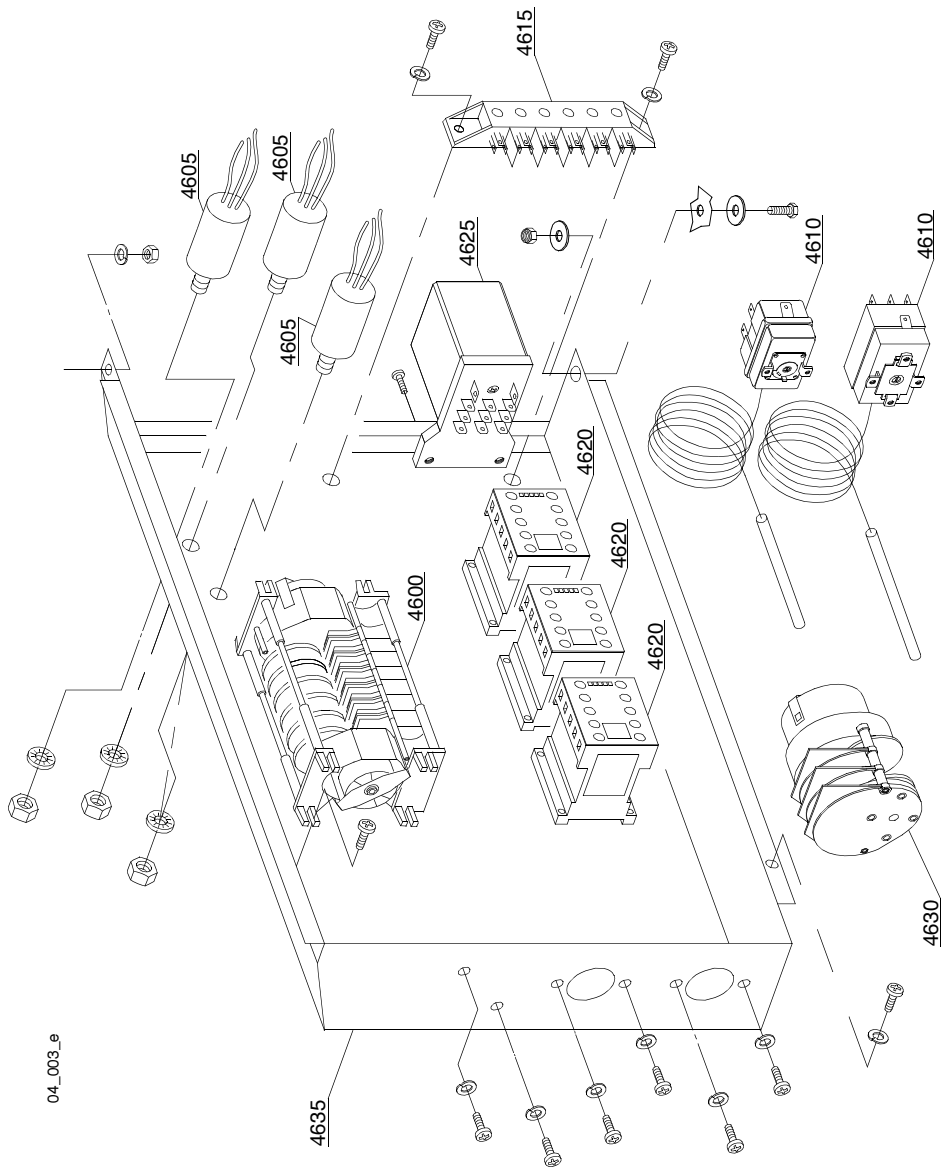

04\_003\_e



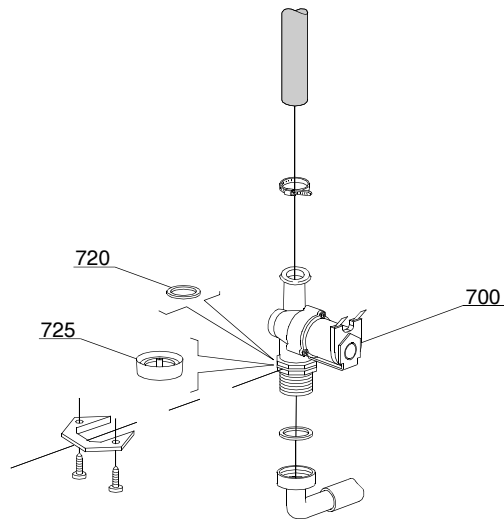

05\_002\_e

## Spare parts

---

ID	P-code	Model	Type	Accessory	Voltage	Description
MODULE:Solenoid valve group						
700	10703		29P			Single solenoid valve
720	N.C.		29P			Pression reducing valve



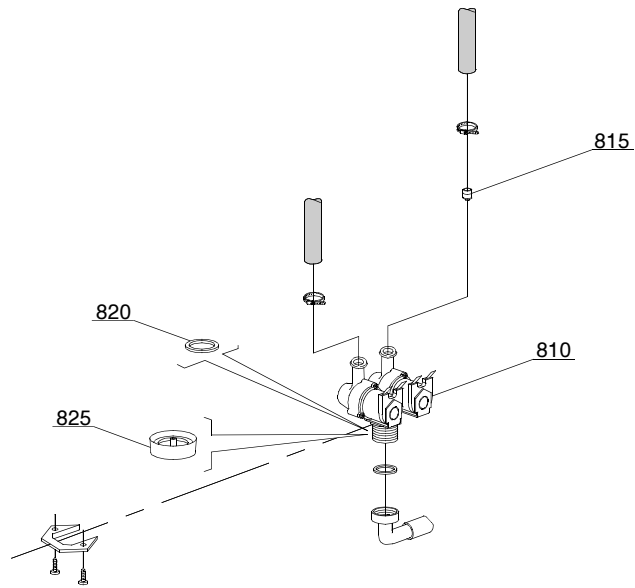

05\_003\_e

## Spare parts

ID	P-code	Model	Type	Accessory	Voltage	Description
MODULE:Solenoid valve group						
810	15098		29P	cr,ws		Double solenoid valve - Ø10
815	15115		29P	cr,ws		Green pression solenoid valve
820	N.C.		29P	cr,ws		Pression reducing valve

06\_002\_e

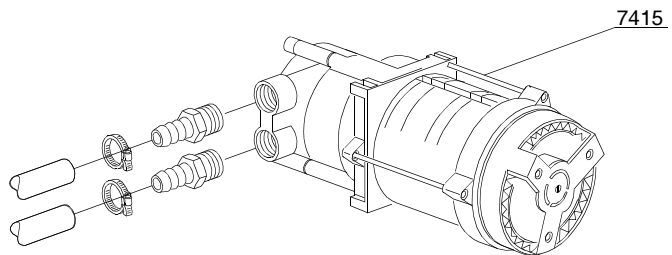
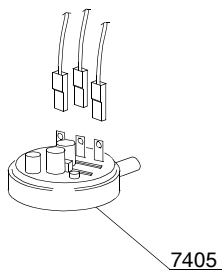
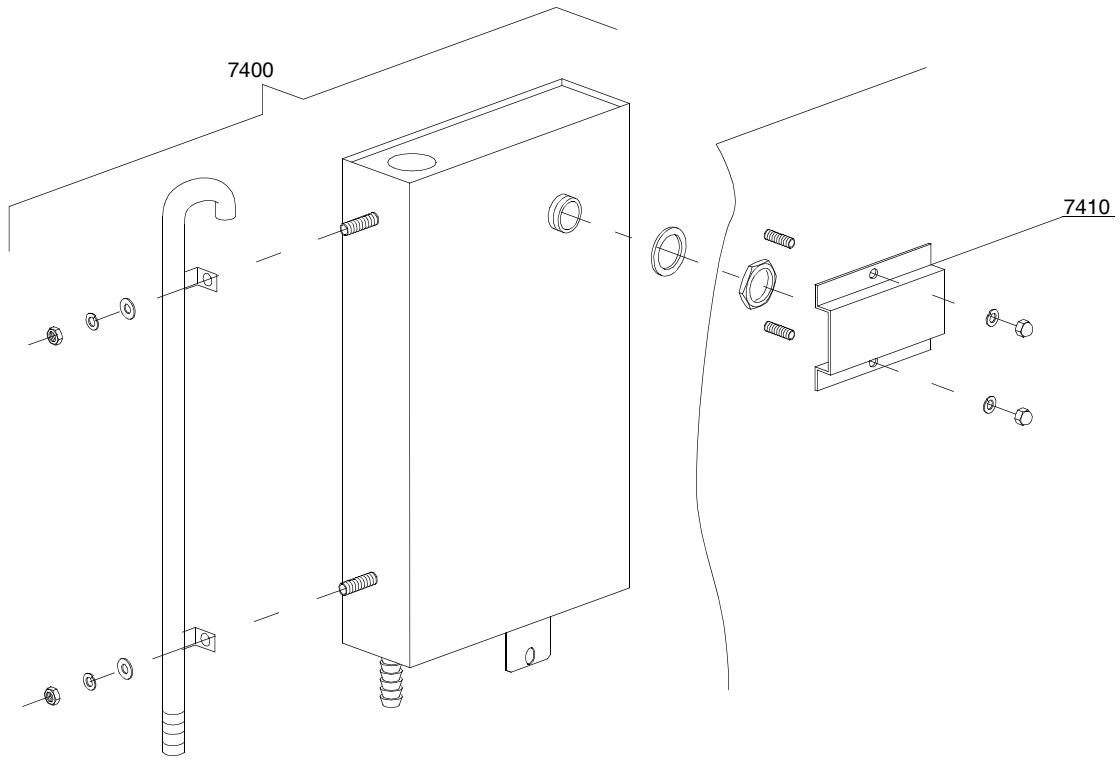

## Spare parts

---

ID	P-code	Model	Type	Accessory	Voltage	Description
MODULE:Break Tank						
7400	15735		29P	bt		Break tank assembly
7405	10706/A		29P	bt		47-27 pressure switch
7410	15738		29P	bt		Hole protection
7415	15100/D		29P	bt		Booster pump

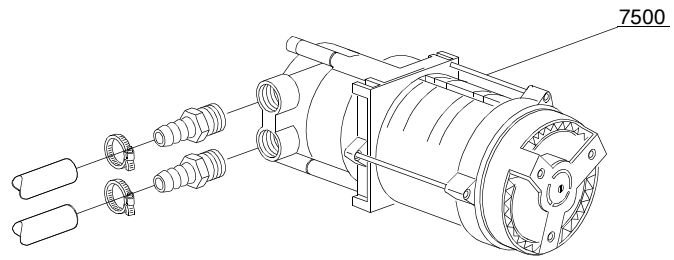

07\_003\_e

**Spare parts**

---

ID	P-code	Model	Type	Accessory	Voltage	Description
MODULE:Booster pump						
7500	15100/D		29P	bp		Booster pump

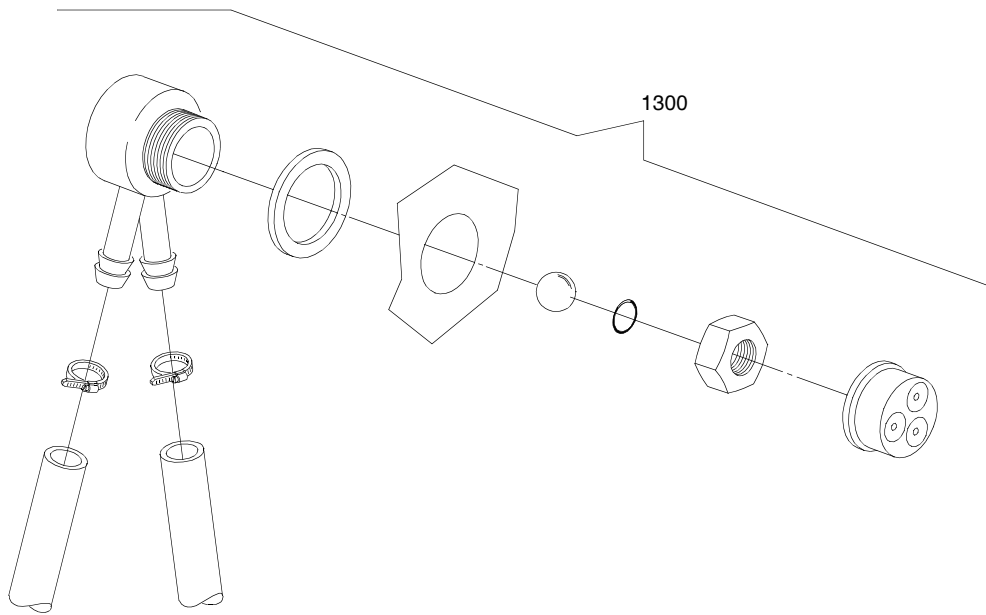

08\_005\_e

**Spare parts**

---

ID	P-code	Model	Type	Accessory	Voltage	Description
MODULE:DVGW						
1300	999900006		29P	dvgw		DVGW assembly



09\_001\_e

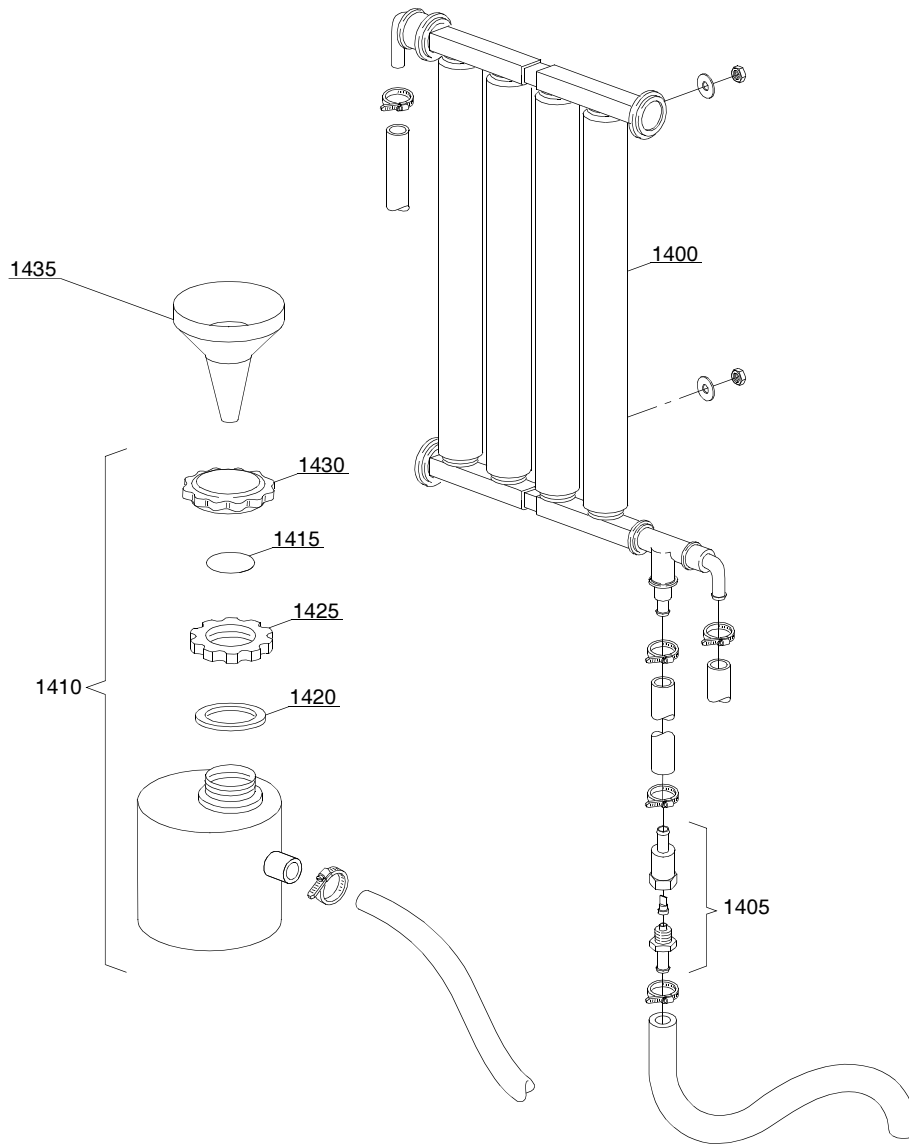

## Spare parts

ID	P-code	Model	Type	Accessory	Voltage	Description
MODULE:Water softner group						
1400	16066		29P	ws		4 elements water softner
1405	16070		29P	ws		Nonreturn valve
1410	16065		29P	ws		Salt container
1415	16067/A		29P	ws		OR gasket
1420	16067/B		29P	ws		Gasket
1425	16067/C		29P	ws		Ring nut
1430	16067/D		29P	ws		Plug
1435	16082		29P	ws		Funnel

10\_002\_e

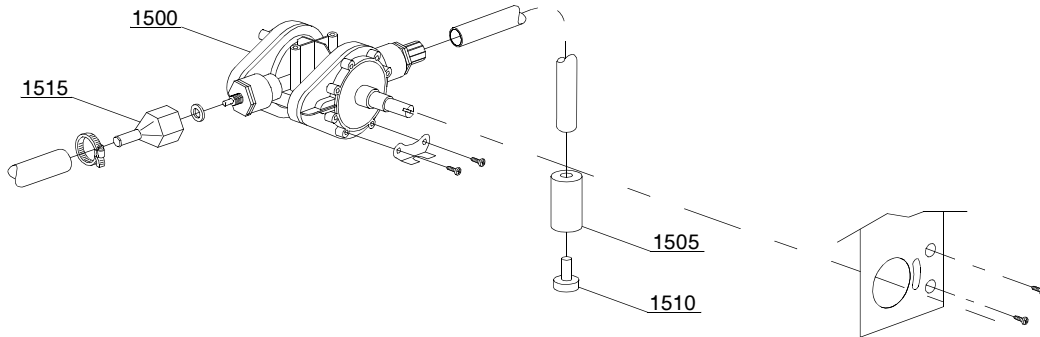

**Spare parts**

ID	P-code	Model	Type	Accessory	Voltage	Description
MODULE:Shining product dosing device group						
1500	10798		29P			Shining product dosing device
1505	12525		29P			Counter-weight
1510	15058		29P			Small filter
1515	10798/B		29P			Brass pipe fitting

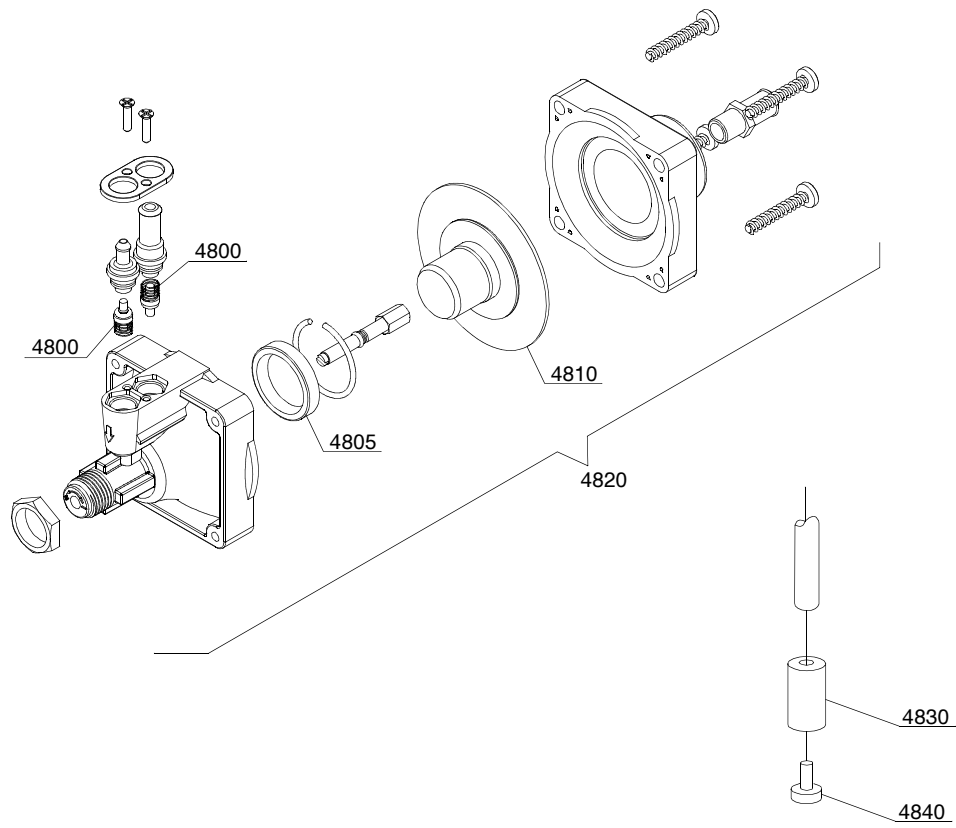

10\_004\_e

## Spare parts

ID	P-code	Model	Type	Accessory	Voltage	Description
MODULE:Shining product dosing device group						
4800	10805		29P			Tecnopro dosing valve
4805	10806		29P			Ø22 gasket
4810	10807		29P			Membrane
4820	10799		29P			Shining product dosing device
4830	12525		29P			Counter-weight
4840	15058		29P			Small filter

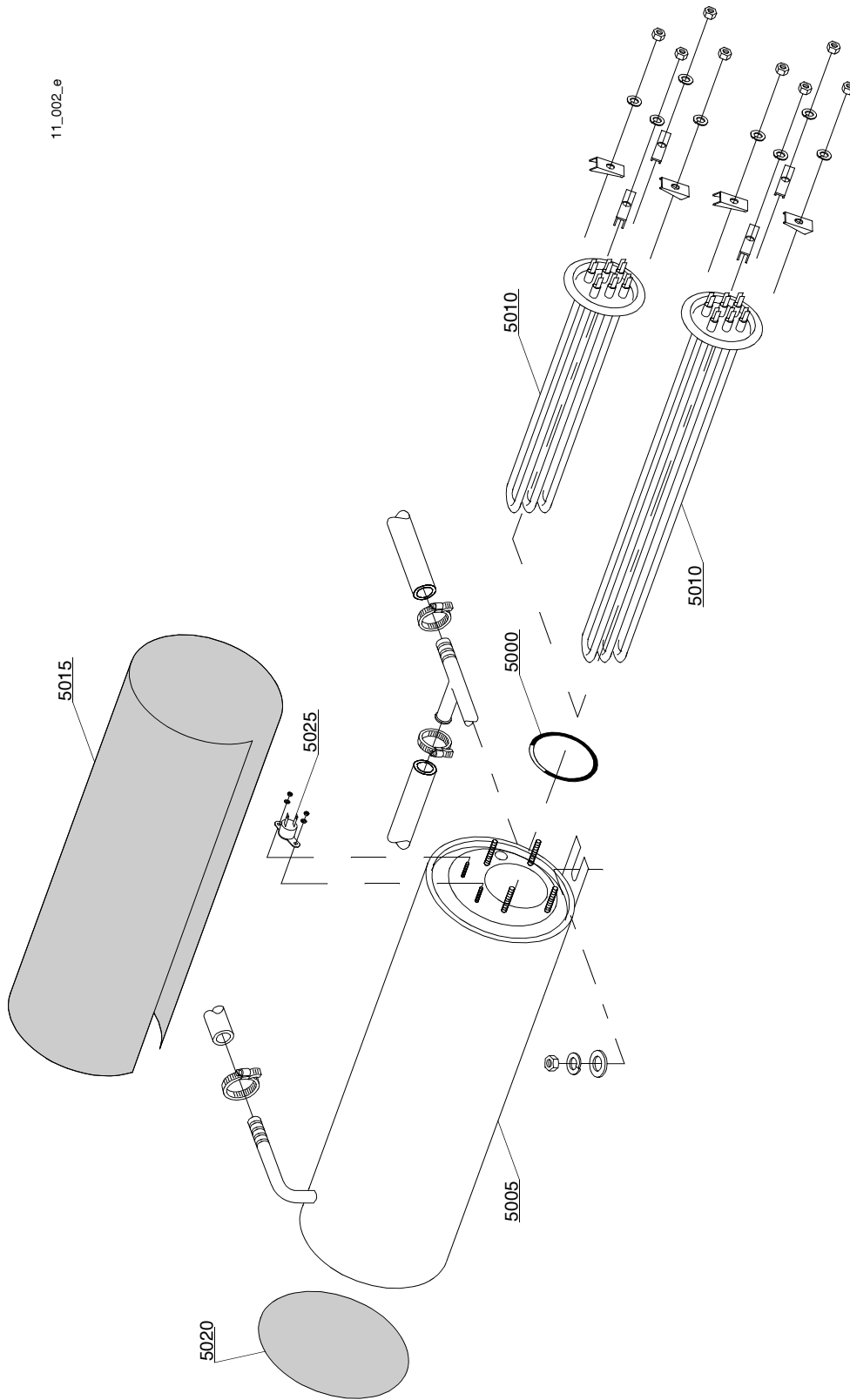

## Spare parts

ID	P-code	Model	Type	Accessory	Voltage	Description
MODULE:Boiler group						
5000	13005		29P			OR 151 NBR gasket
5005	150905		29P			Boiler
5010	15089		29P			4,5KW heating element
5010	15089/E		29P			6KW - 230V heating element
5010	15046		29P			3KW heating element
5015	15066		29P			Insulating boiler
5020	15205		29P			Ø160 bottom
5025	15550		29P			Safety thermostat



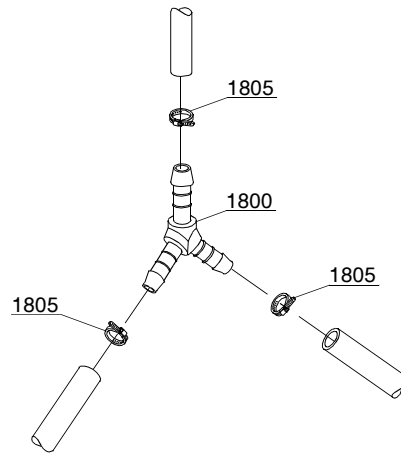

12\_003\_e

## Spare parts

---

ID	P-code	Model	Type	Accessory	Voltage	Description
MODULE:3 ways derivation						
1800	540091		29P			Ø12 mm plastic 3 ways derivation
1805	11807		29P			12/22 clamp

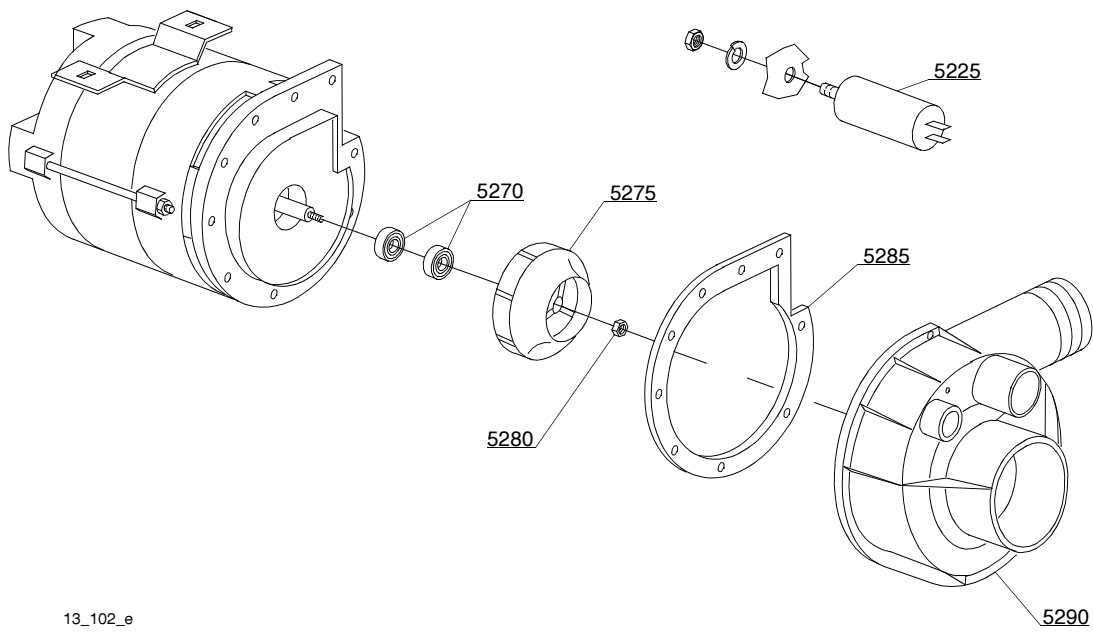
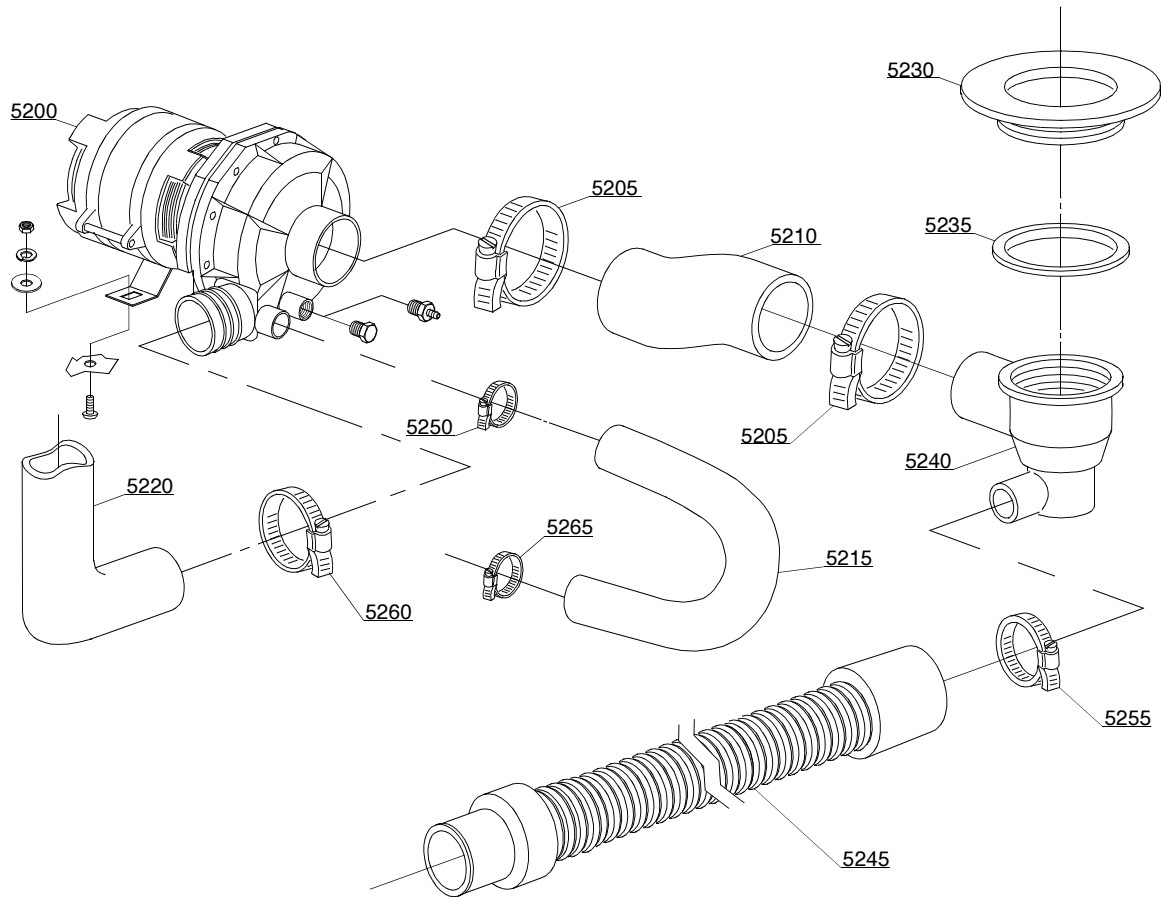

13\_102\_e

Spare parts

ID	P-code	Model	Type	Accessory	Voltage	Description
MODULE:Wash pump						
5200	15908/A		29P		A	0,75Hp wash pump
5200	15908/M		29P		I	0,75Hp - 60Hz wash pump
5200	15908/O		29P			0,75Hp - 200Vac 50Hz wash pump
5200	15908/D		29P			1Hp - 200Vac 50Hz wash pump
5205	11824		29P			50/70 clamp
5210	25032		29P			Suction pipe coupling
5215	560014		29P			Pump/lower wash turret delivery pipe
5220	560008		29P			Top delivery pipe
5225	15081		29P			12,5 uF condenser
5230	500601		29P			Ring nut
5235	80208		29P			95x75x3 gasket
5240	500606		29P			Right side scrap tray
5245	10727		29P			Drain pipe
5250	11806		29P			25/40 clamp
5255	11807		29P			12/22 clamp
5260	11810		29P			40/60 clamp
5265	11809		29P			30/45 clamp
5270	15080/C		29P			Rotating seals
5275	15079/B		29P			Pump rotor
5280	11724		29P			M6 stainless steel nut
5285	15079/D		29P			Gasket
5290	15031/E		29P			Scroll

14\_002\_e

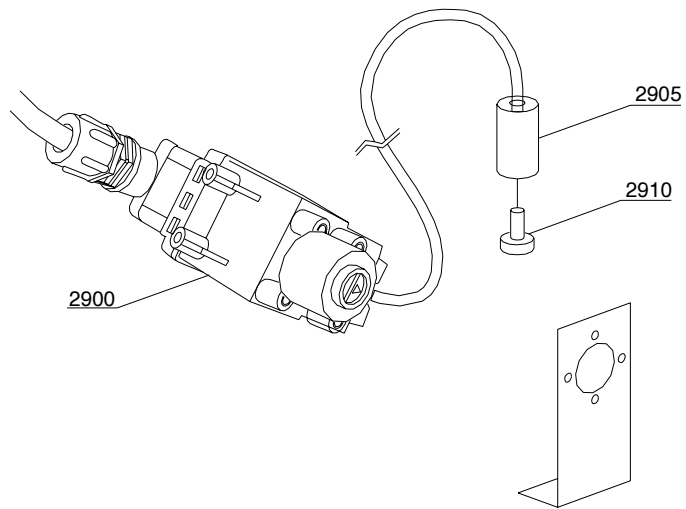
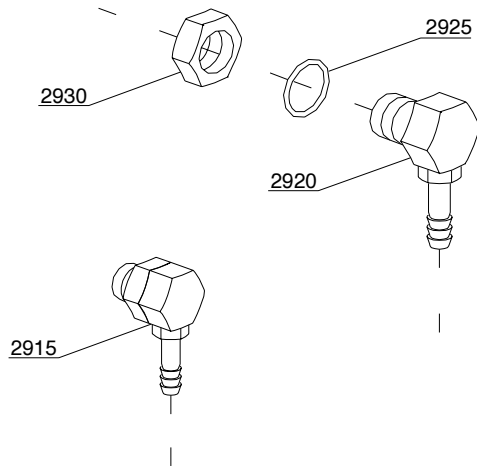

## Spare parts

---

ID	P-code	Model	Type	Accessory	Voltage	Description
MODULE:Dosing device group						
2900	15108/L		29P	dd		Lang dosing device
2905	12525		29P	dd		Counter-weight
2910	15058		29P	dd		Small filter
2915	15123		29P	dd		Compleat plastic injector
2920	15148		29P	dd		Steel injector
2925	15159		29P	dd		OR gasket
2930	10200205		29P	dd		M12x1 stainless steel nut

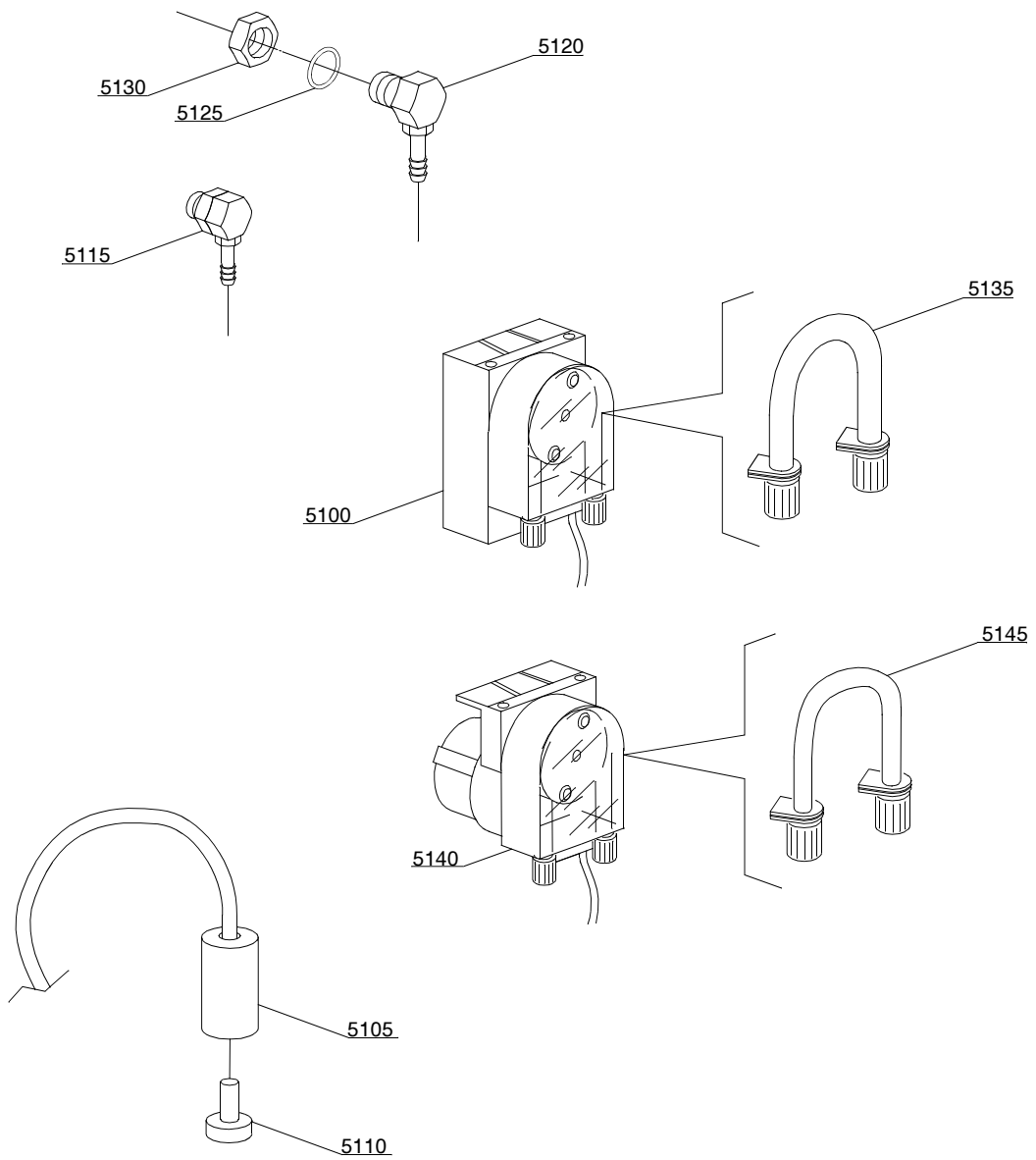

14\_004\_e

## Spare parts

ID	P-code	Model	Type	Accessory	Voltage	Description
MODULE:Dosing device group						
5100	15985		29P	dd		Seko dosing device
5105	12525		29P	dd		Counter-weight
5110	15058		29P	dd		Small filter
5115	15123		29P	dd		Complet plastic injector
5120	15148		29P	dd		Steel injector
5125	15159		29P	dd		OR gasket
5130	10200205		29P	dd		M12x1 stainless steel nut
5135	15185		29P	dd		Seko thermoplastic pipe
5140	15985		29P	dd		Germac dosing device
5145	15108/E		29P	dd		Germac thermoplastic pipe



15\_002\_e

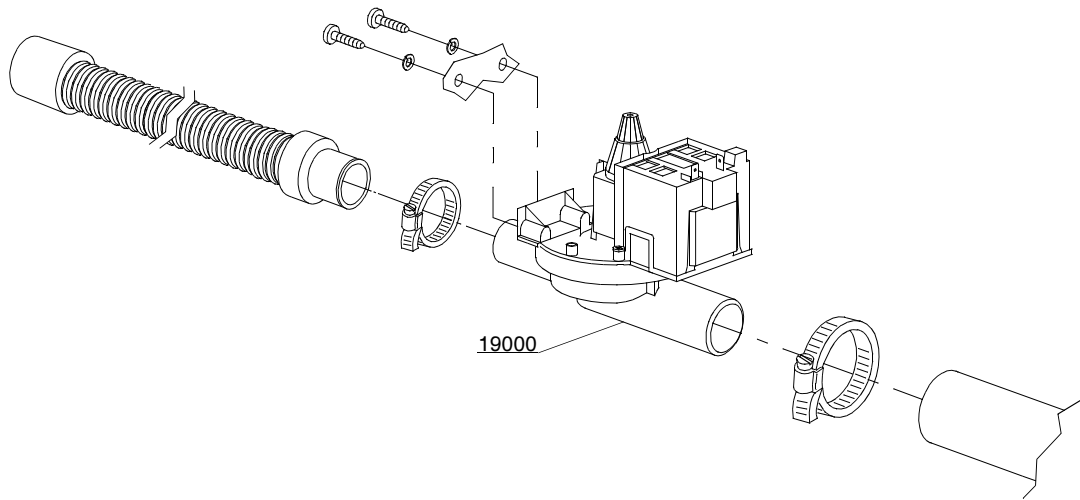

## Spare parts

---

ID	P-code	Model	Type	Accessory	Voltage	Description
MODULE:Drain pump group						
19000	15101/A		29P	dp	A	Drain pump - 50Hz
19000	15101/B		29P	dp		Drain pump - 60Hz

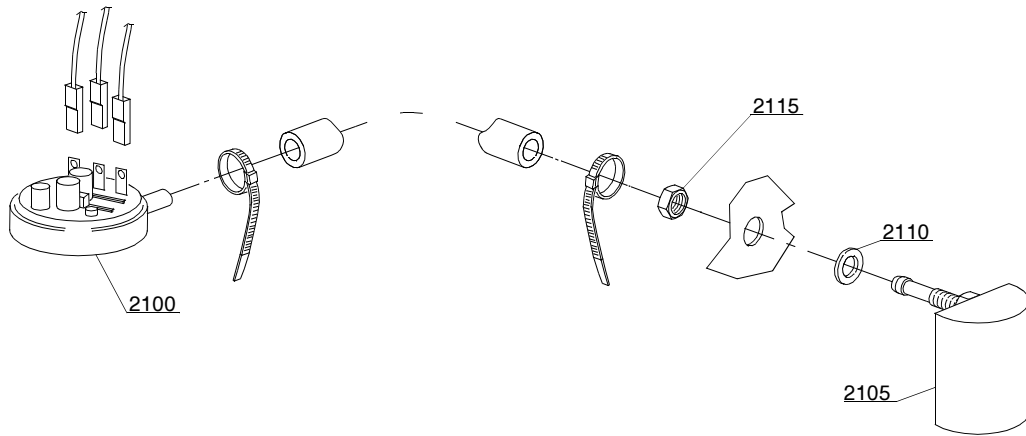

16\_001\_e

## Spare parts

ID	P-code	Model	Type	Accessory	Voltage	Description
MODULE:Pressure switch group with air trap						
2100	10706/A		29P			47-27 pressure switch
2105	10911/D		29P			Air trap assembly
2110	13301		29P			Gasket
2115	11702		29P			M8 stainless steel nut

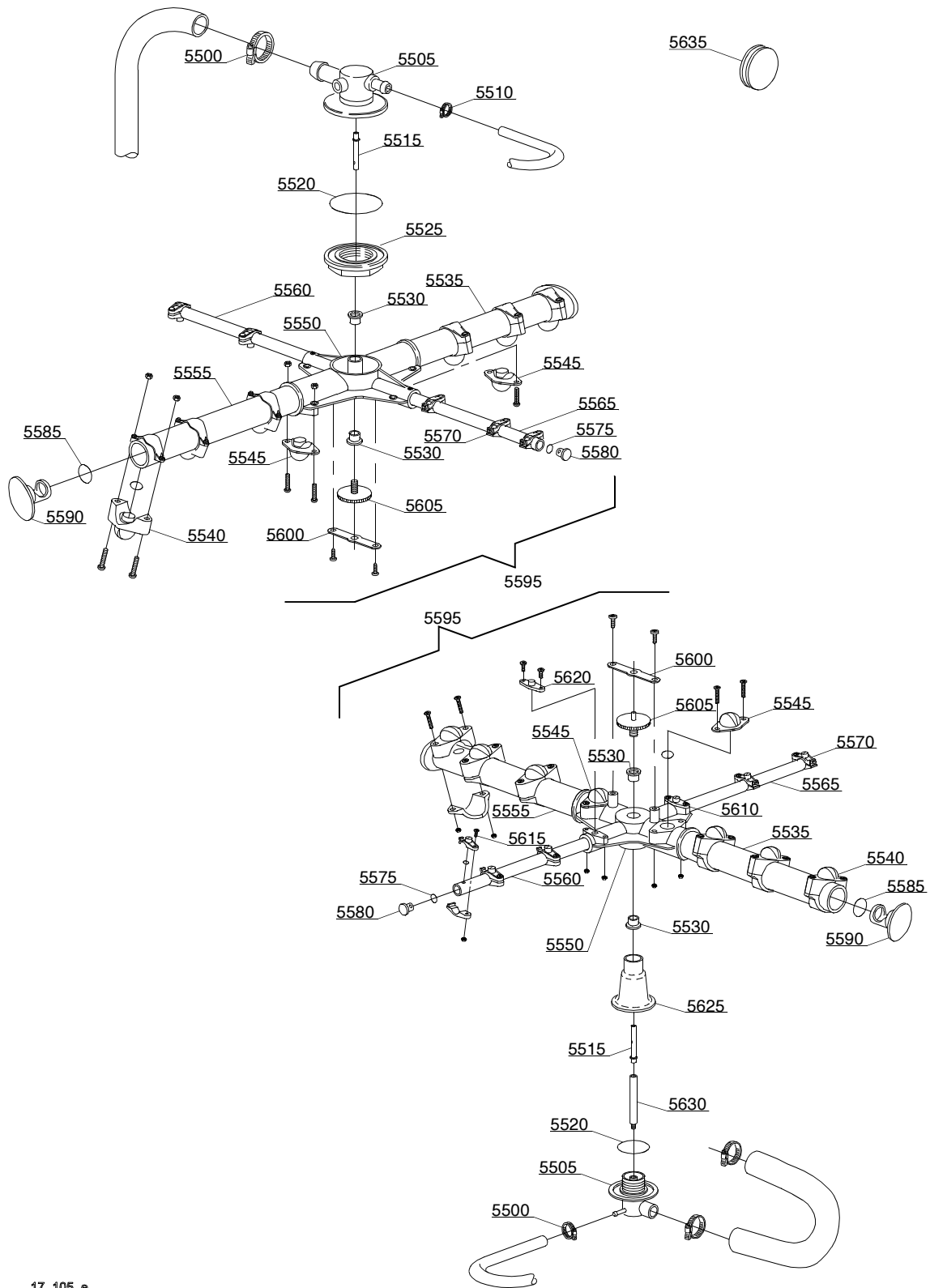

17\_105\_e

## Spare parts

ID	P-code	Model	Type	Accessory	Voltage	Description
MODULE:Turret group with rotating arms						
5500	11806		29P			25/40 clamp
5505	500612		29P			Top/lower turret
5510	11807		29P			12/22 clamp
5515	15300		29P			Ø10x51 lower/top rinse axle
5520	13015		29P			6225 OR 160 NBR gasket
5525	500610		29P			Ring nut for fixing turret
5530	13319		29P			Sliding washer
5535	15571		29P			Ø28 right wash pipe
5540	10211		29P			Ø28 raised nozzle
5545	10218		29P			Ø28 opened plane nozzle
5550	10209		29P			4 ways big rotor
5555	15572		29P			Ø28 left wash pipe
5560	15575		29P			Right rinse pipe
5565	15576		29P			Left rinse pipe
5570	12528		29P			Ø10 complet rinse nozzle
5575	13016		29P			2018 OR 103 NBR gasket
5580	12532		29P			Ø10 plastic plug
5585	13018		29P			OR 2087 NBR gasket
5590	10257		29P			Ø28 plastic plug
5595	15956		29P			Ø28 wash/rinse group
5600	10210		29P			Blocking ring nut rotor plaque
5605	11101/I		29P			Stainless steel group fixing screw
5610	10217		29P			Ø10 closed plane nozzle
5615	11004		29P			4x10 TCB Ø8 spax toothed screw
5620	10213		29P			Ø10 opened plane nozzle
5625	560004		29P			Lower pipe coupling
5630	560005		29P			Lower rinse axle
5635	13316/A		29P			DVGW hole gasket