

easicook.co.uk

Spare Parts Manual

**Leading UK Distributors
of Catering Equipment Since 1977**

Sales - Repairs - Spares

Tel: 029 20747567

Fax: 029 20214100

Email: info@easicook.co.uk

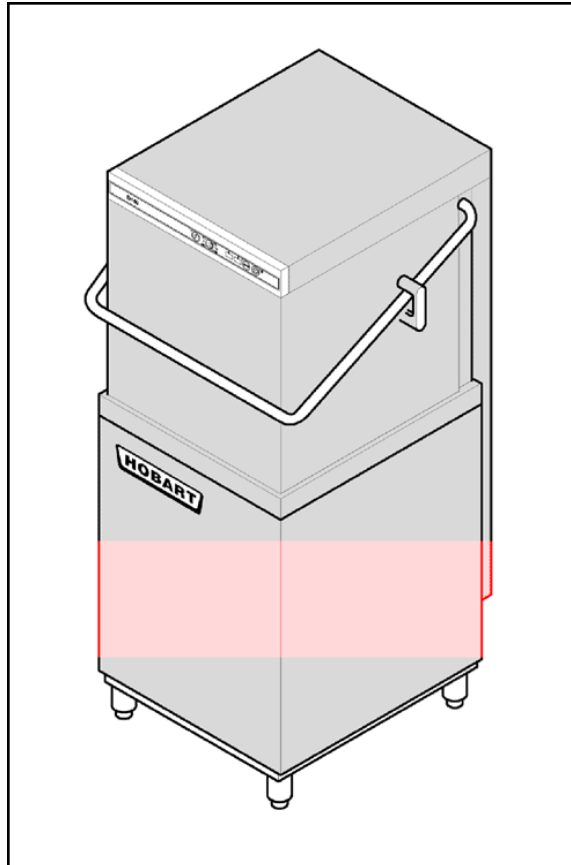

**CHH50
CHH60
CHH70
Dishwasher**

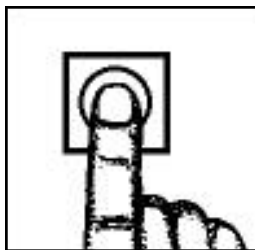

Installation / Operation

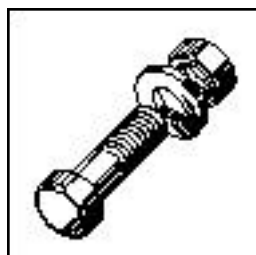

Spare Parts List

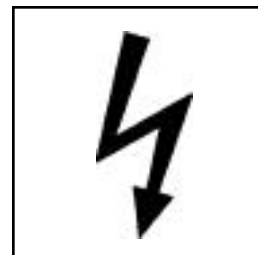

Wiring Diagram

**CONTENTS**

CHAP.1 INTRODUCTION	3
CHAP.2 INSTALLATION.....	3
2.1 HANDLING AND UNPACKING.....	3
2.2 ELECTRICAL CONNECTION.....	4
2.3 WATER CONNECTION.....	4
2.4 DRAIN CONNECTION.....	5
2.5 ADJUSTMENTS	5
2.6 RINSE-AID DISPENSER	5
2.7 DETERGENT	6
CHAP.3 SAFETY RECOMMENDATIONS.....	7
3.1 RESIDUAL RISKS AND WARNINGS	7
3.2 SAFETY DEVICE.....	7
CHAP. 4 USE OF MACHINE.....	8
4.1 DESCRIPTION OF THE COMMANDS	8
4.1.1 Automatic water drainage (optional).....	9
4.2 USING THE MACHINE	9
4.3 END OF CYCLE OPERATIONS.....	10
CHAP.5 MAINTENANCE.....	11
5.1 GENERAL RULES.....	11
5.2 PERIODIC MAINTENANCE (TO BE DONE AT LEAST EVERY 20 DAYS).....	11
CHAP.6 DISMANTLING	12
6.1 DISMANTLING THE MACHINE	12

CHAP.1 INTRODUCTION

The warnings contained in this manual provide important information for safely installing, using and servicing this machine.

The operator is required to read this manual before starting any operation involving handling, installation, use, maintenance or disassembly of the machine. This manual must be kept intact and in a safe place for frequent consultation.

CHAP.2 INSTALLATION

2.1 HANDLING AND UNPACKING



- Move the machine very carefully using a forklift.
- Make sure the equipment is not damaged, if it is immediately inform the dealer and shipper. If in doubt do not use the machine until it has been checked by professionally trained personnel.
- Move the machine to the site where it will be used and remove the packing.

Packing materials (plastic bags, polystyrene, nails) can be dangerous and must be kept out of the reach of children.

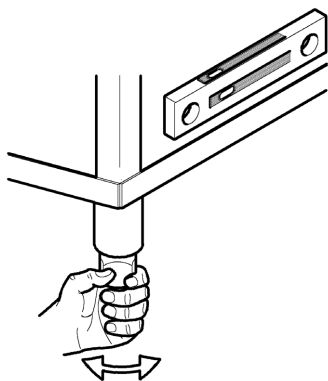

- The installation must be carried out according to the manufacturer's instructions and by professionally trained personnel.
 - Only a fixed connection is suitable for this equipment.
 - Position the machine and level it perfectly using the feet.
 - The flooring must be suitable for the overall weight of the machine.
 - Follow the indications on the installation drawing and set-up the electrical, water and drain systems in the wash area.
-



2.2 ELECTRICAL CONNECTION

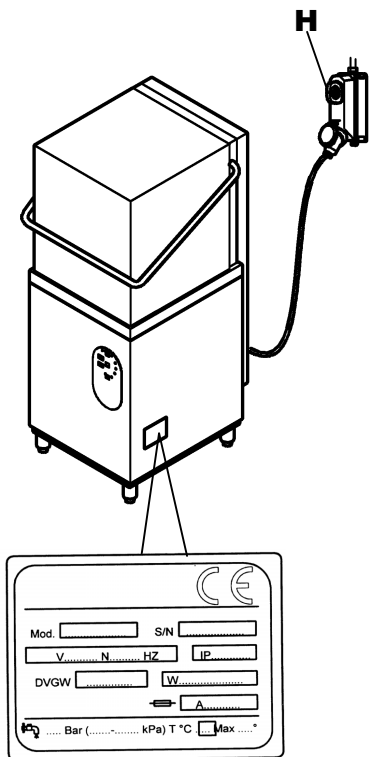

1. Connection to the power supply must be made with a main switch (H) it must be omnipolar and interrupt all contacts including neutral. There must be a distance of at least 3 mm between open contacts, and it must have a thermal magnetic safety switch or fuses which are able to withstand the maximum power indicated on the plate.
2. Make sure that the power supply corresponds to that on the technical features plate on the right side of the machine.
3. Use an effective earthing system in compliance with local laws to protect the safety of the operators and not damage the machine.
4. Do not use adapters, multiple sockets or extension cords.
5. The equipment must be included in an equipotential system, and connected using a screw marked with the symbol. The equipotential wire must be 10 mm².



If the power supply cable (provided with the equipment) needs to be replaced use another H07RN-F type with the same dimensions.

For additional information see the wiring drawing.

2.3 WATER CONNECTION

Set-up the site according the attached plumbing drawing.

Before connecting the equipment make sure that a gate valve has been placed between the water supply and the equipment so that the water can be turned off if required or for repair work.

Use a hose to connect the solenoid valve (E) to the gate valve (V) and make sure that the delivery is not less than 20l/min.

Check that the temperature and water pressure correspond to what is shown on the technical specifications plate.

If the water is harder than what is listed in the chart, it is advisable to install a decalcifier upline from the solenoid valve.

If there are high concentrations of very conductive minerals in the water, it is advisable to install a demineralization system calibrated to the hardness shown in the following chart.

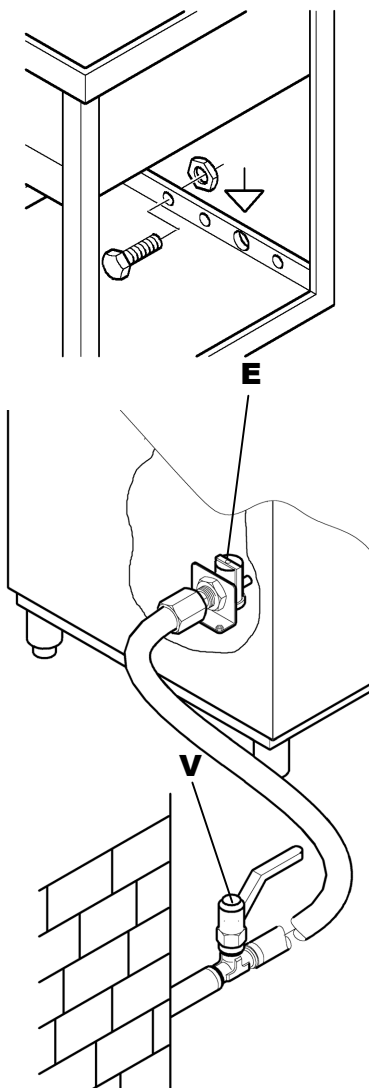



	Specification		From	To
Hardness	French degrees	f	5	10
	German degrees	°dH	4	7'5
	English degrees	°e	5	9,5
	Parts per million	ppm	70	140
Residual Minerals	Maximum	mg/l	300/400	



2.4 DRAIN CONNECTION

Gravity for all models, except EH70, so the drain needs to be situated below the base of the machine. Model EH70 requires a stand-pipe

The drain pipe needs to be connected to a drain-trap built into the floor.

The drain dimensions are shown in the installation drawing.

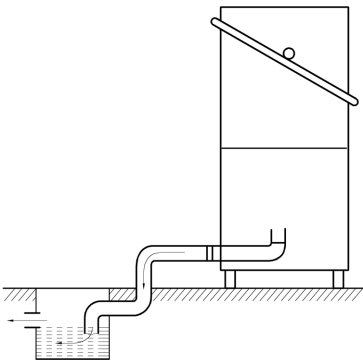

2.5 ADJUSTMENTS AND CHECKS

The temperature of the wash tank is regulated by a fixed thermostat at about 55° C. This temperature ensures proper action by the chemicals contained in industrial dishwashing detergents.

The boiler temperature set by a fixed thermostat is about 85° C.

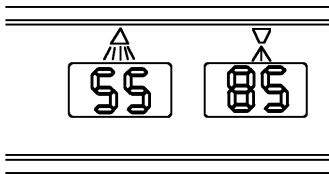

2.6 RINSE-AID DISPENSER

Before adjusting, the dispenser and hose need to be filled using the primer button (A).

To adjust use the ring nut (B) situated at the center of the dispenser, rotating clockwise reduces the quantity, counterclockwise increases it.

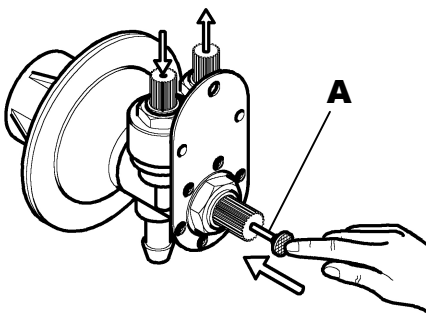

The dispenser must not operate empty

An excessive amount of rinse agent causes bluish stripes on the dishes and creates foam in the wash tank.

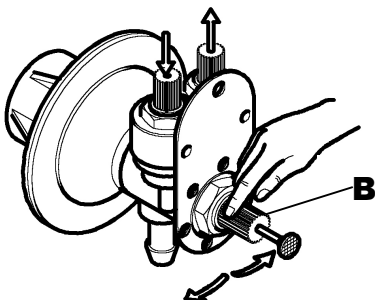

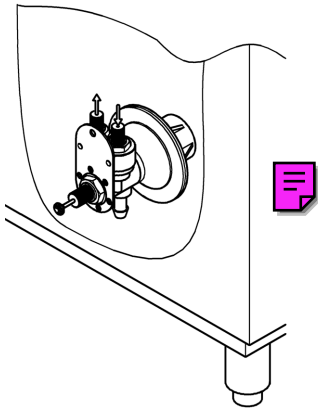

If the glassware is covered with droplets of water and it dries rather slowly this means that the amount of rinse agent is insufficient.

7 cm. of tubing = 1 gram of product

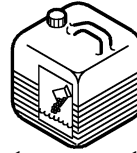

2.1 DETERGENT

Equipment without a detergent dispenser

Put the amount of detergent recommended by the manufacturer into the tank. Depending on the type of detergent this may vary from 2 to 4 gr/lit of water in the tank. Detergent needs to be added approximately every 5 washes as per the manufacturer's instructions.

The above amounts are for water with a hardness of 5-10°F (French degrees).

Models EH60/70 and CHH50 are equipped with detergent dispenser

Regulations:

A trimmer (A) allows to determine the «ON-OFF» time and consequently the amount of detergent required.

- Turning the adjustment trimmer clockwise or counter-clockwise will respectively decrease or increase the amount of rinse aid it delivers.
- To optimise the calibration, evaluate the results of some washing cycles.



BE CAREFUL!

The level in detergent tank must not get empty or filled with corrosive or inadequate products.

The warranty does not cover damages caused by an improper use of dispenser.

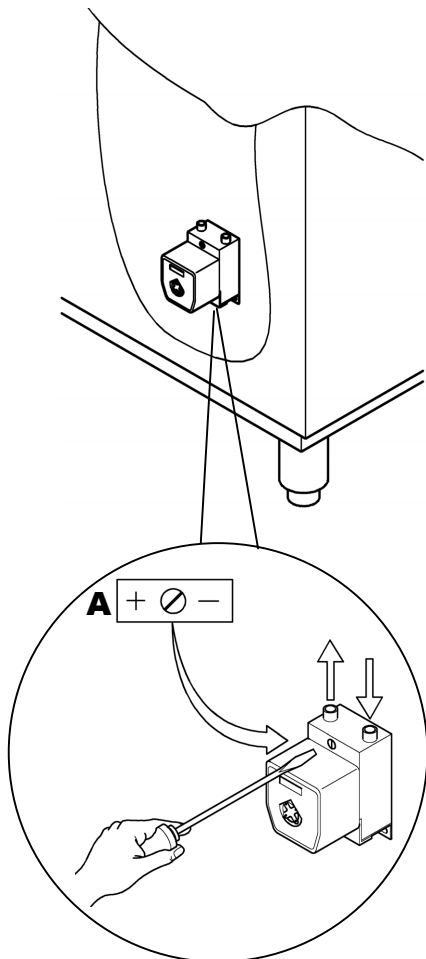

CHAP.3 SAFETY RECOMMENDATIONS



3.1 RESIDUAL RISKS AND WARNINGS

- Never open the door quickly if the cycle has not finished.
- Do not put bare hands into the wash solution.
- Never remove the machine panels if the power upline has not been turned off.
- The professionally trained personnel who install the machine and connect the electricity, will explain to the user how to operate the machine and which safety measures to use.
- The installer will provide practical demonstrations and leave written instructions which are provided with the machine.



- **This machine is only to be used for the purpose for which it was designed. Any other use is considered improper and dangerous.**
- The machine is not to be used by untrained personnel.
- Never use the machine if any of the protections (microswitches, panels or other) provided by the manufacturer are missing.
- Do not use the machine to wash objects not compatible with those indicated by the manufacturer.
- All repair work must be done by the manufacturer or an authorized service center using original spare parts.
- Failure to observe this may affect the safety of the machine.
- The power supply should be turned off when the machine is not being used.

3.2 SAFETY DEVICE

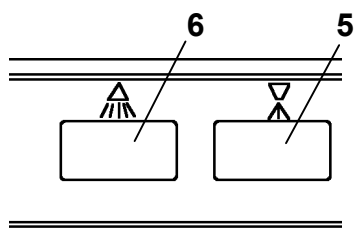

The board can recognize various breakdowns.

Faults are easily seen from the messages on the screen (5 and 6) and from any interruption of the operations in progress only in cases (1 and 3) listed below

WARNING! Turning the machine off and then on again resets the warning, which will appear again if the problem has not been resolved.

Display on the Message

	PROBLEM:	Tank (6)	Boiler (5)
1	TANK NOT FILLED OR OVERFILLED (if ≥ 10 min have elapsed, correct level of water has not been reached in the tank)	Er	04
2	BOILER PROBE FAILURE (if the probe is not connected correctly or damaged) (if the probe is short circuited or damaged)	Er Er	07 08
3	OVERTEMPERATURE (excessive boiler and tank temperature) (intervention safety thermostat)	Hi SA	Hi FE
4	RINSE (Rinse not effected) (Insufficient rinse pressure) (Excessive rinse pressure)	Er Pr Pr	01 01 02
5	TANK PROBE FAILURE (if the probe is not connected correctly or damaged) (if the probe is short circuited or damaged)	Er Er	05 06
6	BOILER (Boiler resistor failure) (Heating overtime)	Er	03



Chap. 4 USE OF MACHINE

4.1 DESCRIPTION OF THE COMMANDS

1

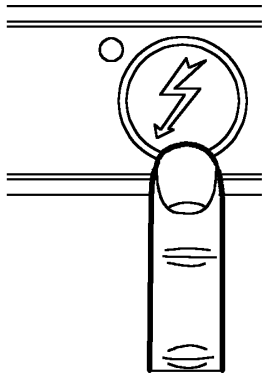

- 1. To turn the machine on, press the button indicated at left/right (the corresponding warning light will light up).

2

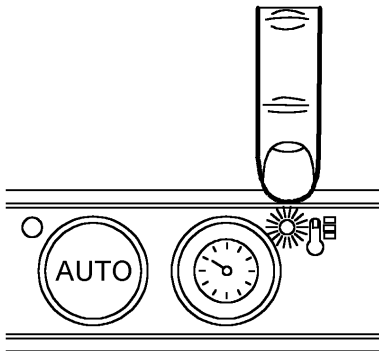

- 2. When the light turns off, the machine is ready to use.

3

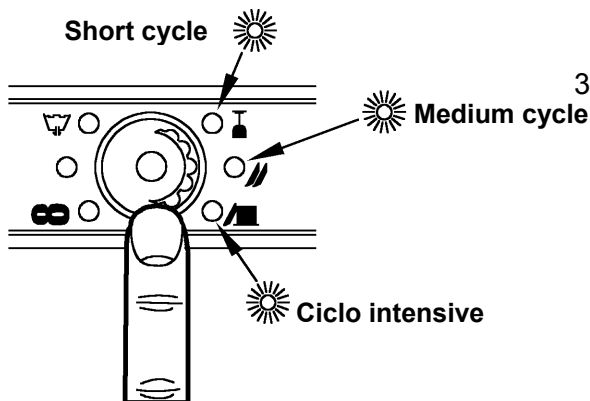

- 3. Press the button indicated at left/right to select the items to wash. The light turns on in accordance with the amount of time selected. **NB: choose the " ∞ " for longer wash cycles.**

4

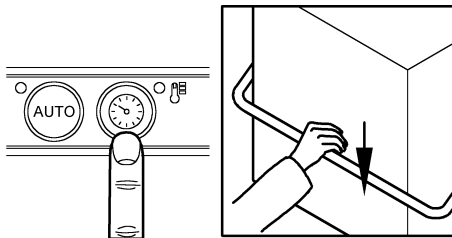

- 4. Press the button indicated at left/right and close the door, the machine will start automatically. **NB: press the button to interrupt the " ∞ " cycle (repeat sequence 3 for new wash programs).**

5

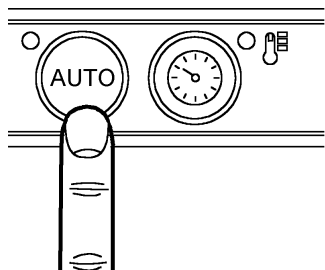

- 5. If you want cycles to start when you close the hood, push the button and the corresponding light will turn on



1

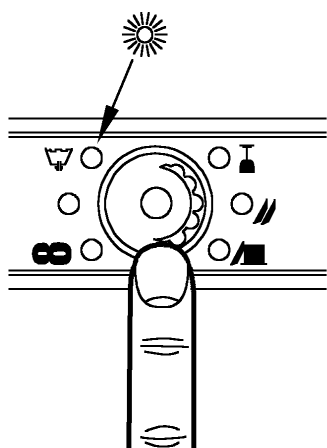

4.1.1 Automatic water drainage (optional)

1. Press the button indicated at left/right and select the drainage programme (the corresponding warning light will light up).

2

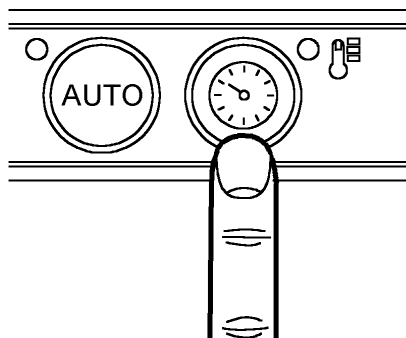

2. Press the button indicated at left/right and the machine will automatically drain the water out of the machine.

4.2 USING THE MACHINE

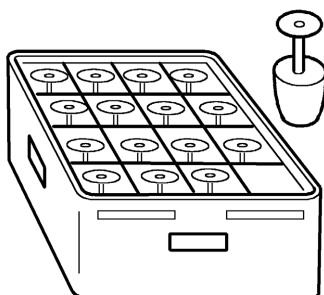

Pour the proper amount of detergent in the wash tank according to the producer's instructions.

The detergent must be the industrial type or possibly foamless.

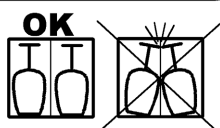

Never put your bare hands in the wash water; place the cups and the glasses upside down in the baskets. Place the dishes in the proper basket with support pins and their inner surface must be facing up.

Place the silverware and the coffee spoons with the handles facing down.

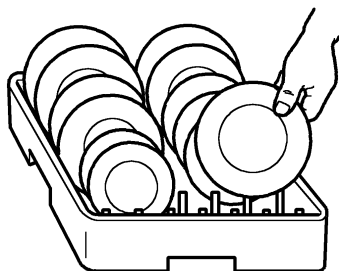

Never place silverware and stainless steel cutlery in the same basket. This could cause the silver to burnish and the stainless steel to corrode.

Use the proper baskets specifically designed for the different type of glassware (dishes, glasses, cups, silverware etc.). To save on detergent and electricity only wash when the baskets are full, but do not overload them. Avoid stacking glassware.

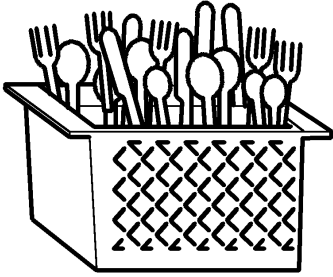

OK

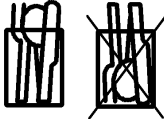

WE RECOMMEND TO PRE-CLEAN the glassware in order to minimize maintenance. The quality of final wash results will be greatly improved by first removing food particles, lemon peels, toothpicks, olive pits, etc. which could partially clog the pump filter and impair washing efficiency.

We recommend washing the glassware before food particles dry on its surface. It is good practice, when dried food waste is involved, to first soak the glassware and silverware before introducing them into the machine.

4.1 END OF CYCLE OPERATIONS

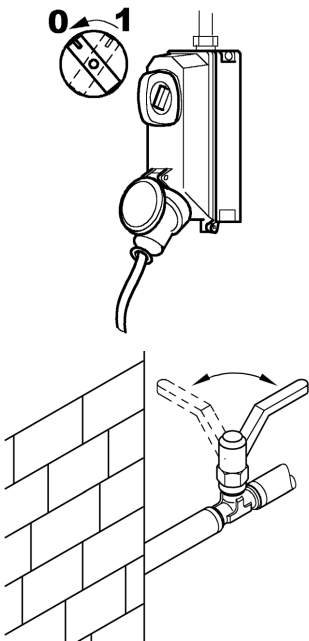

- Remove tension from the machine.
- Lift the hood and extract the rack clean dishes.
- Drain the water from the tank by lifting the overflow-pipe. For the model with drain pump please follow the operations described in the «Use instructions» paragraph.
- Disconnect the main switch of the equipment.
- Close the «rolling shutter valve» for the hydraulic connection.
- Remove the filters clean them under a water jet with a nylon brush.
- Pay attention not to let any dirtiness rests on the bottom of the drain pump filter inside the tank. Clean the tank with a moderate water jet. Wash outside surfaces when are cold with non-abrasive products which are especially studied for steel maintenance.

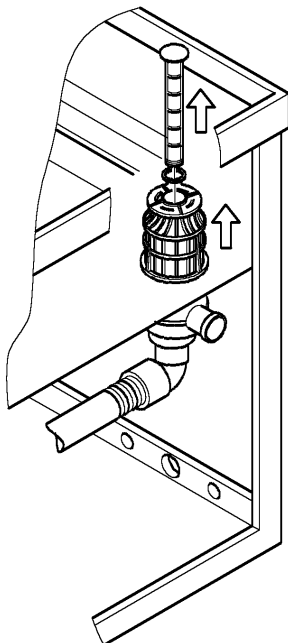

REMARK: Do not wash the equipment with direct jet or at another pressure because eventual infiltrations to the electric components may harm the regular working of the equipment or of the single safety systems, and penalty for this would be the loss of guarantee.

**CHAP. 5 MAINTENANCE****5.1 GENERAL RULES**

The machine are designed to reduce maintenance requirements. It is necessary to observe the following rules to make the machine last long, and work without problems.

In any case, it is necessary to observe the following rules to make the machine stay in perfect working order:

- keep the machine clean and in good condition
- avoid making temporary or urgent repairs frequently

It is very important to observe the maintenance directions; check all the different parts of the machine periodically, so that no anomaly can occur, thus anticipating the time and equipment needed for any maintenance work.

Before cleaning turn off the power.

5.2 PERIODIC MAINTENANCE (to be done at least every 20 days)

To make operations following easier, the rack-holder frame can be removed from its seat.

- Remove the upper and lower rinse arms, by unscrewing the fastening.
 - Unscrew and clean all the sprayers and put them back in their place.
 - Remove the upper and lower wash-arms by unscrewing the rinse pin , clean and rinse them.
 - Remove the wash pump filter, clean it and rinse it.
 - Thoroughly clean the wash tank.
 - Leave the appliance lid open for the whole resting period.
 - Lime deposits and scale will build up on the inner surfaces of the boiler, tank and pipelines due to calcium and magnesium salts present in the water. These scales and deposits can prejudice proper appliance operation.
 - The appliance must be periodically descaled and we recommend that this must be done by an expert.
-

- Grease steel surfaces with vaseline oil whenever the appliance will be inactive for a long period of time.
- Have an expert drain all the water out from the boiler and the wash pump to avoid the danger of ice formation.
-  **If the machine does not operate properly or in case of trouble, call a service center authorized by the manufacturer of the appliance or by his Dealer.**

CHAP. 6 DISMANTLING

6.1 DISMANTLING THE MACHINE

Our machines are not made of materials that require particular disposal procedures.

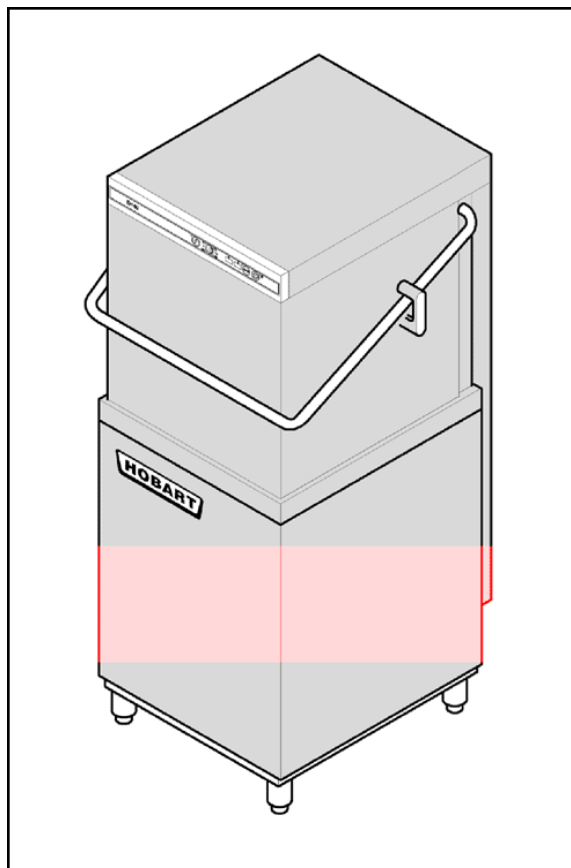

**CHH50
CHH60
CHH70
Dishwasher**

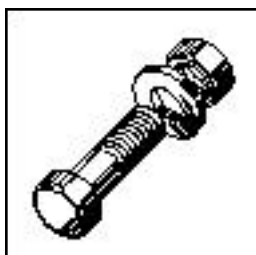

Spare Parts List

Machine Body
Electrical components
Components in the tank
Wash pump

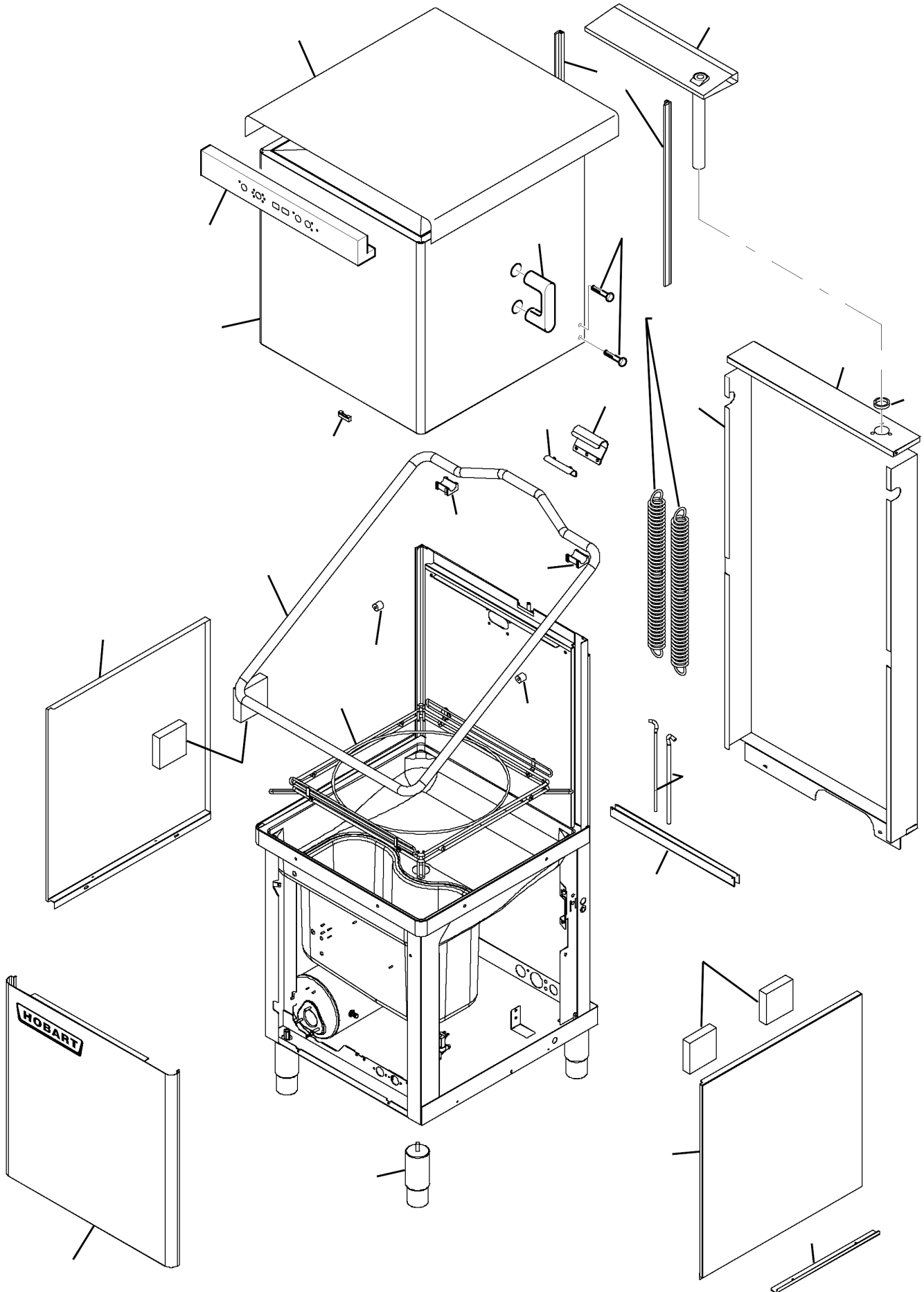

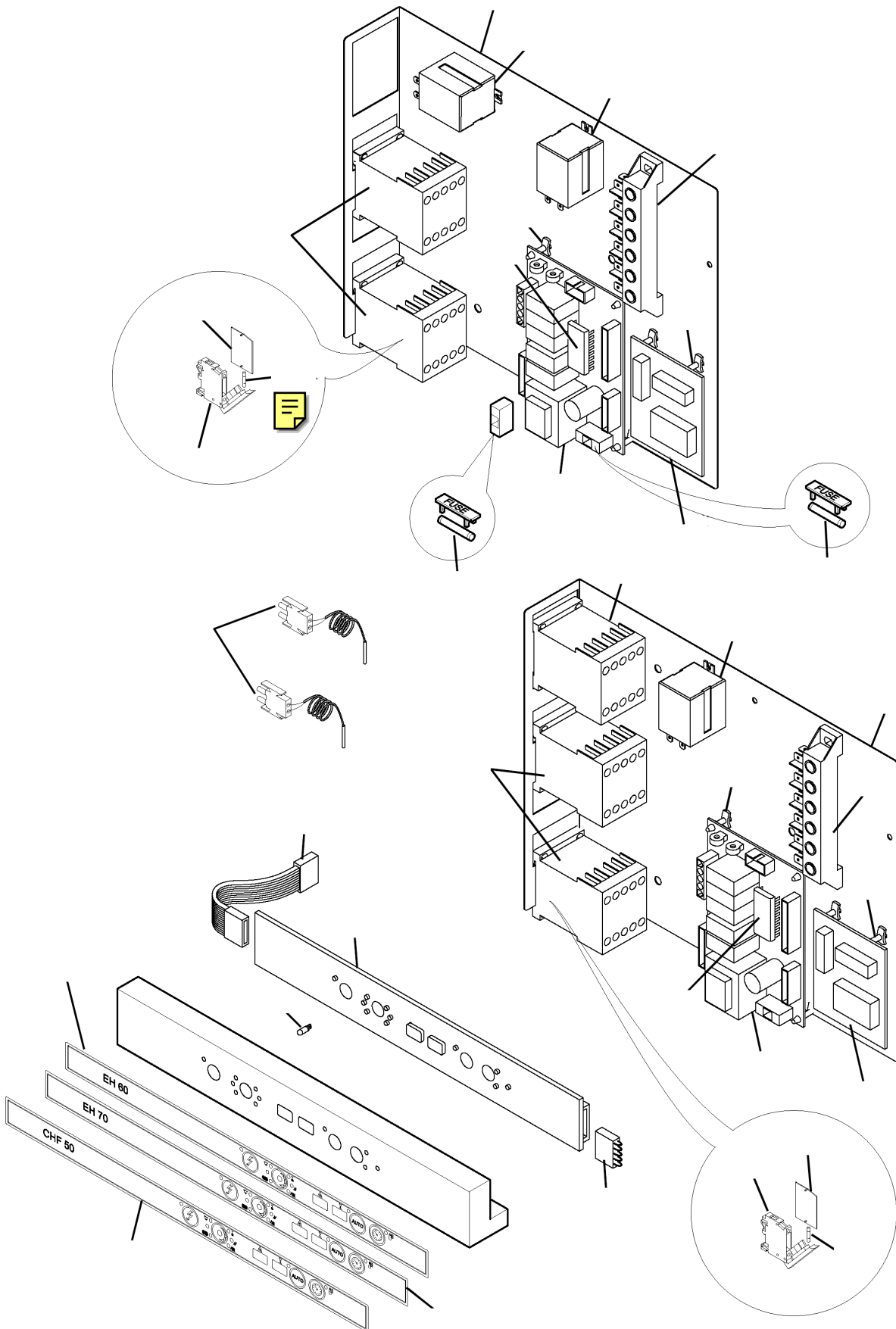

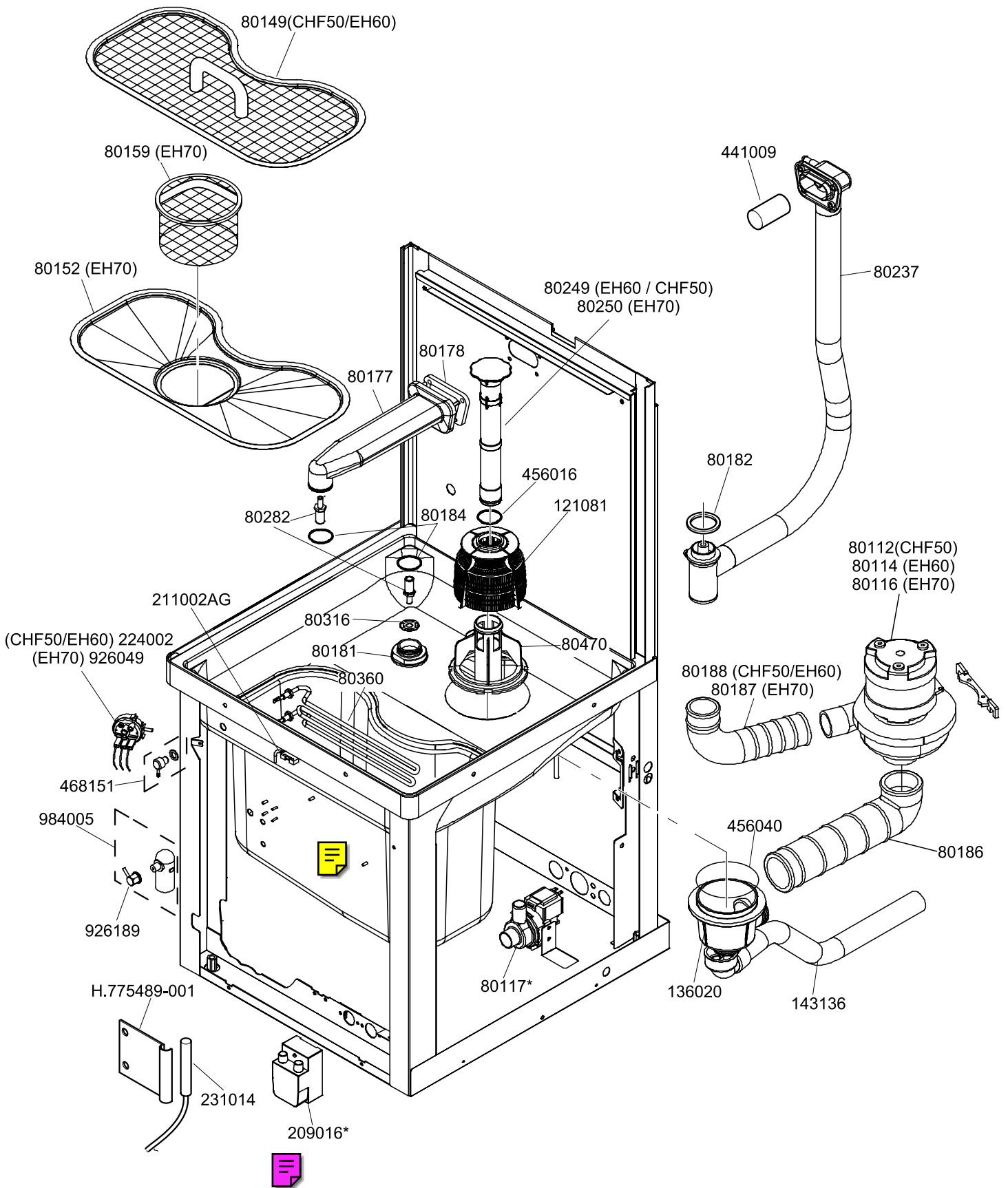

*FITTED AS STD ON

(*) Optional

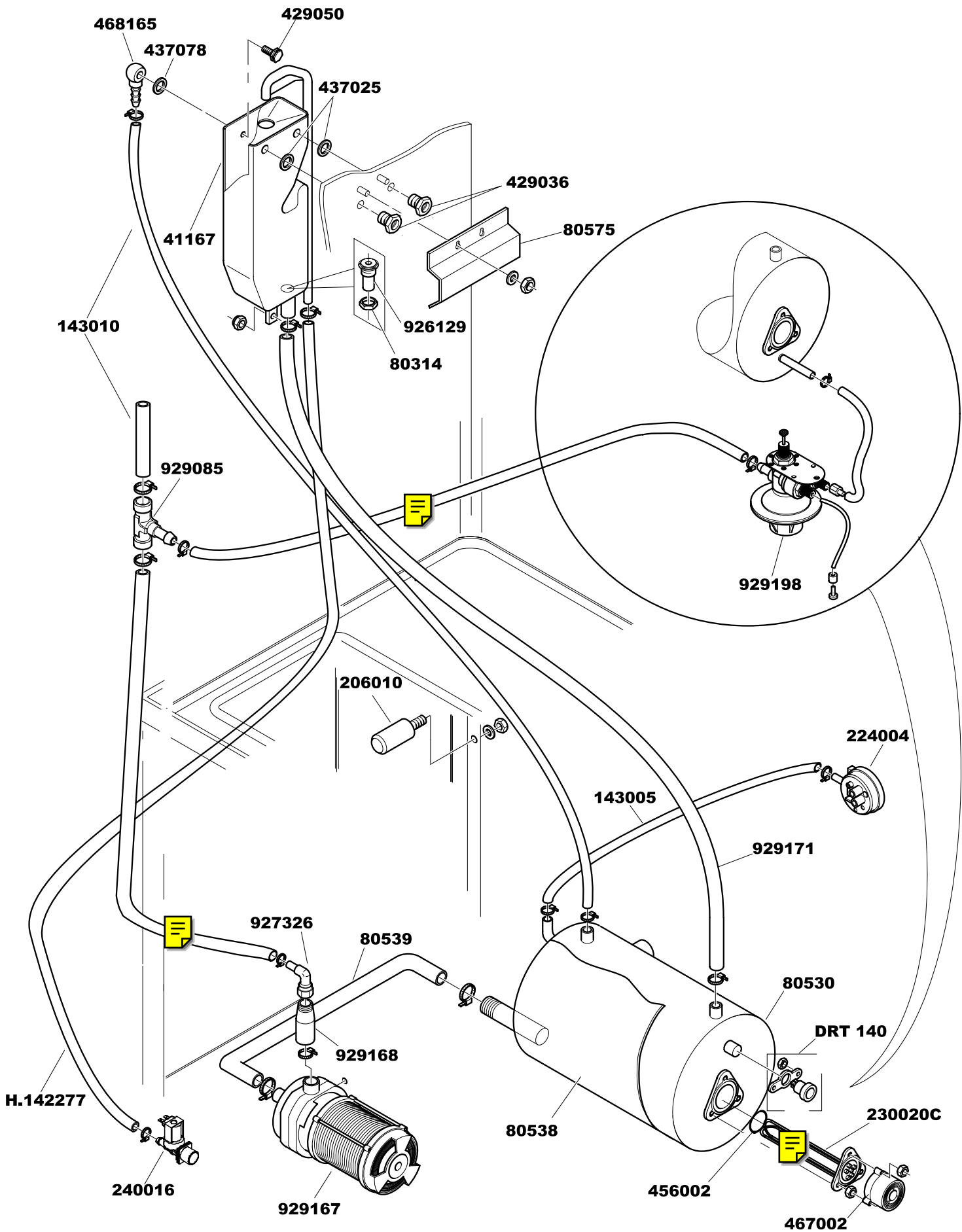

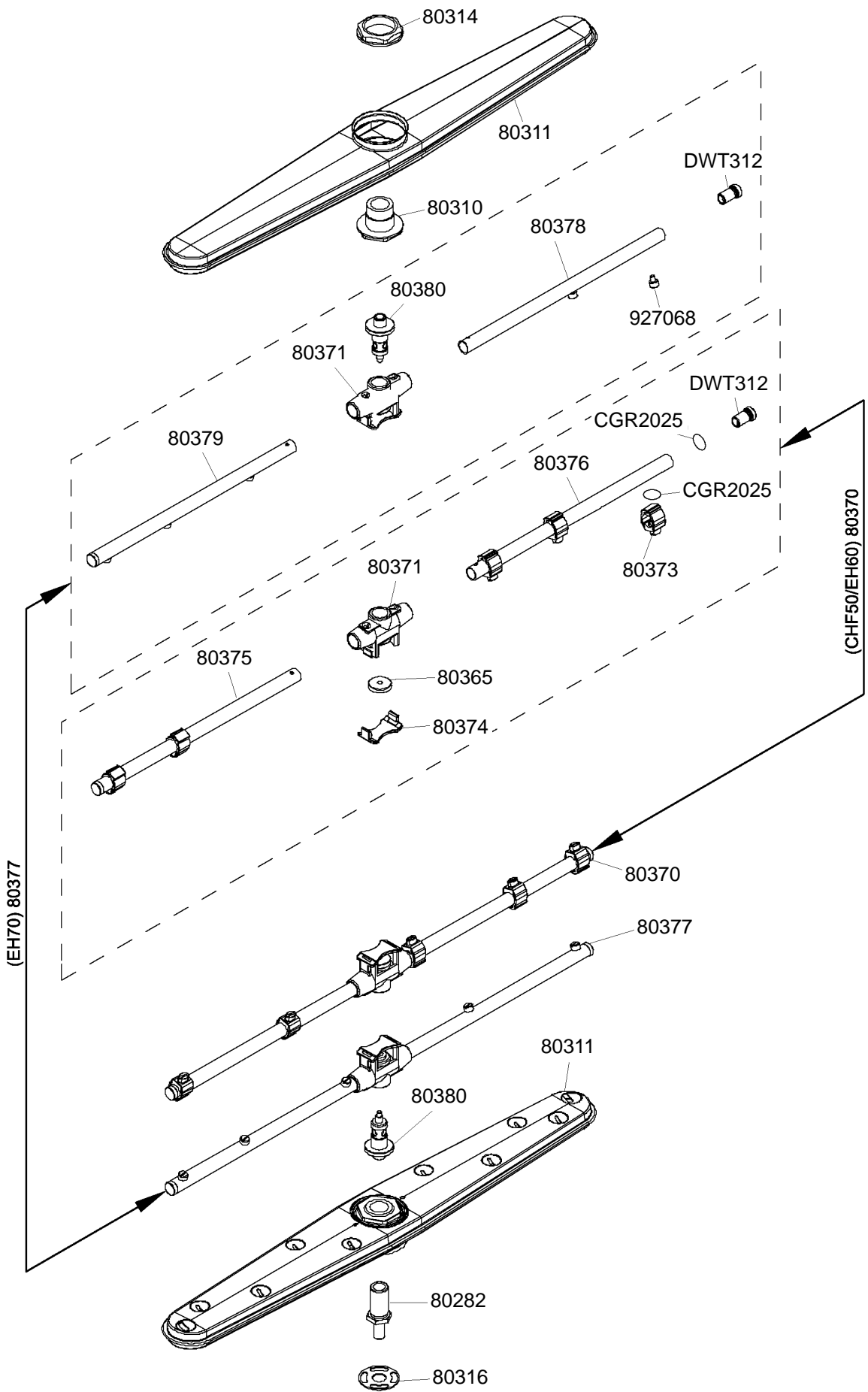

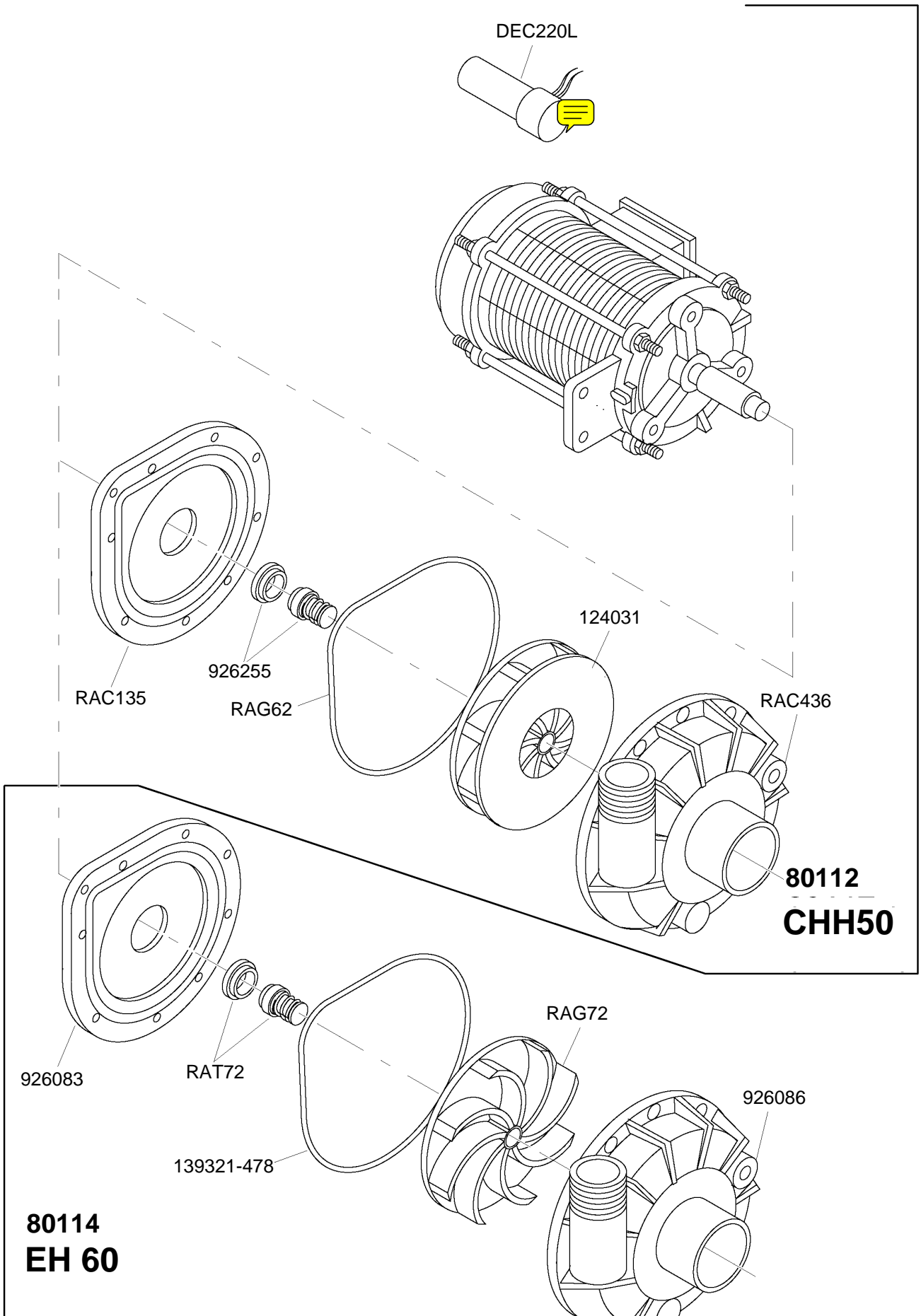

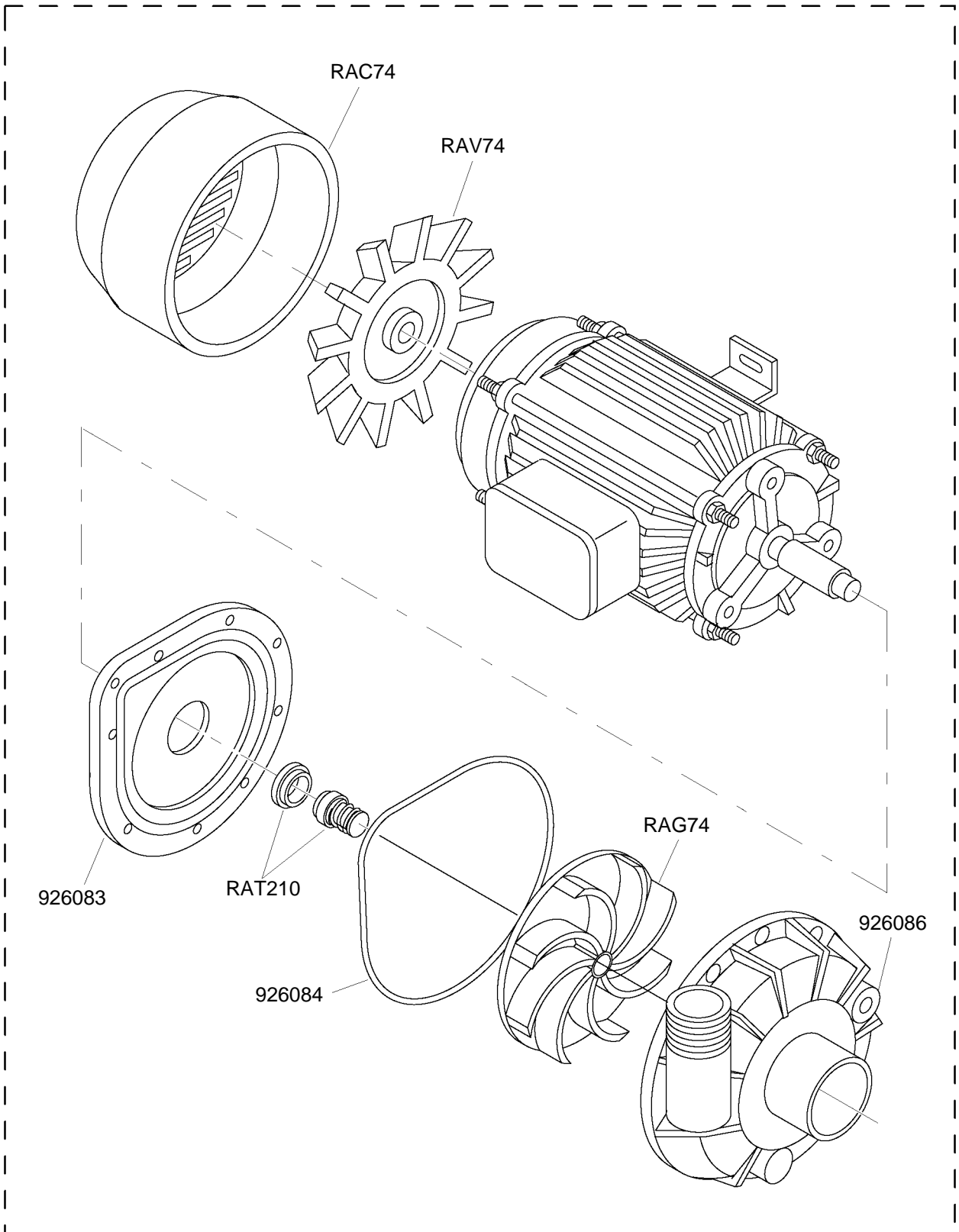

80116
EH 70



23/09/03

Product Modification Note , from today's date we have done the following modification:

Codes subject to the modification

RV82HUK (hobart u.k.)

Modification 's Description

For all hood type models ,
We have exchanged the current pump cod. **139321-472 built by LGB** , with the wash pump
Code 80115 built by FIR.

The two wash pumps are completely interchangeable as a whole part , but
the single internal components will be different , so we have attached the new
spare part catalogue page for the **FIR wash pump code 80115.**



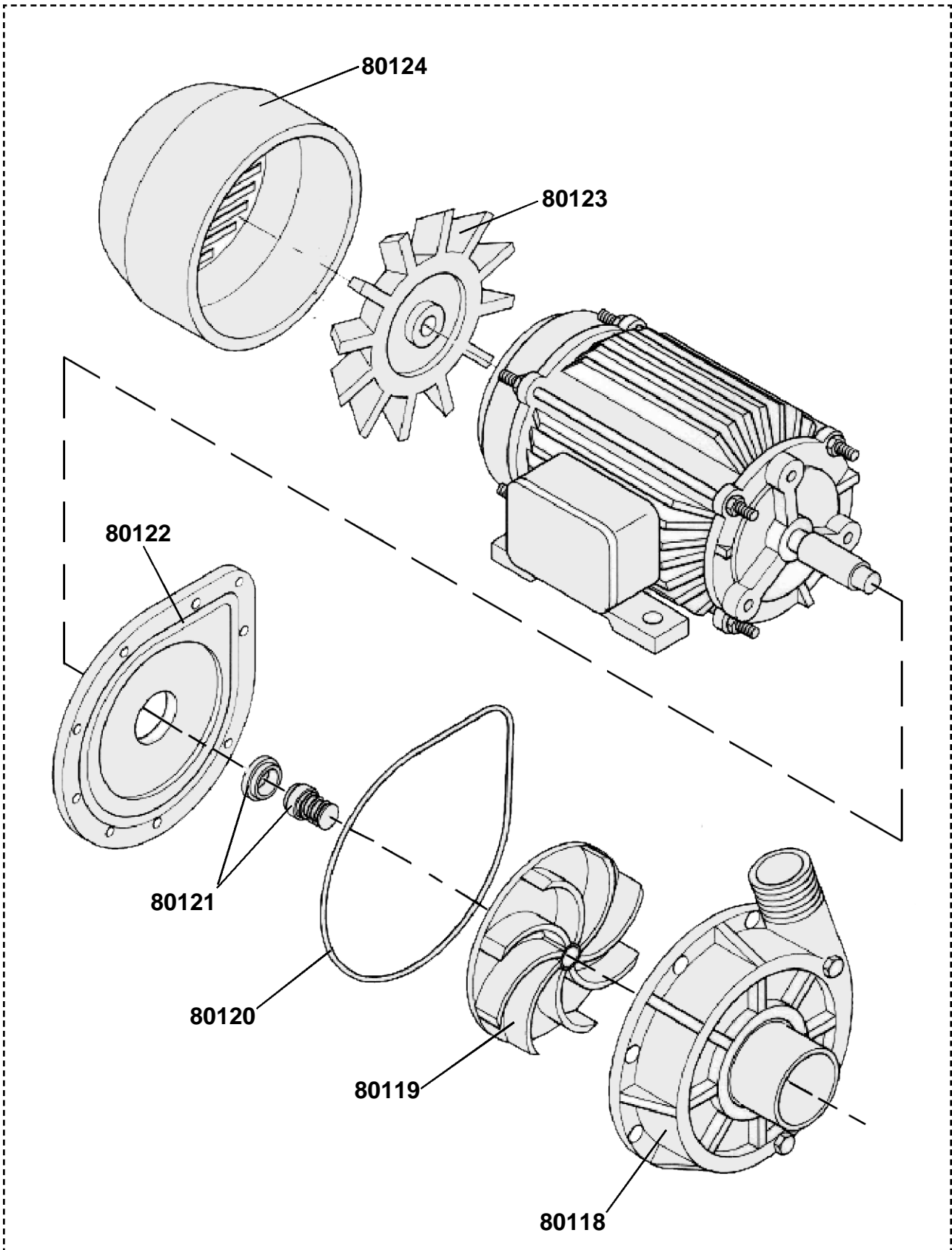

80115 (Fir) Wash Pump Assy
Modification from 23.09.2003
(see att Note)

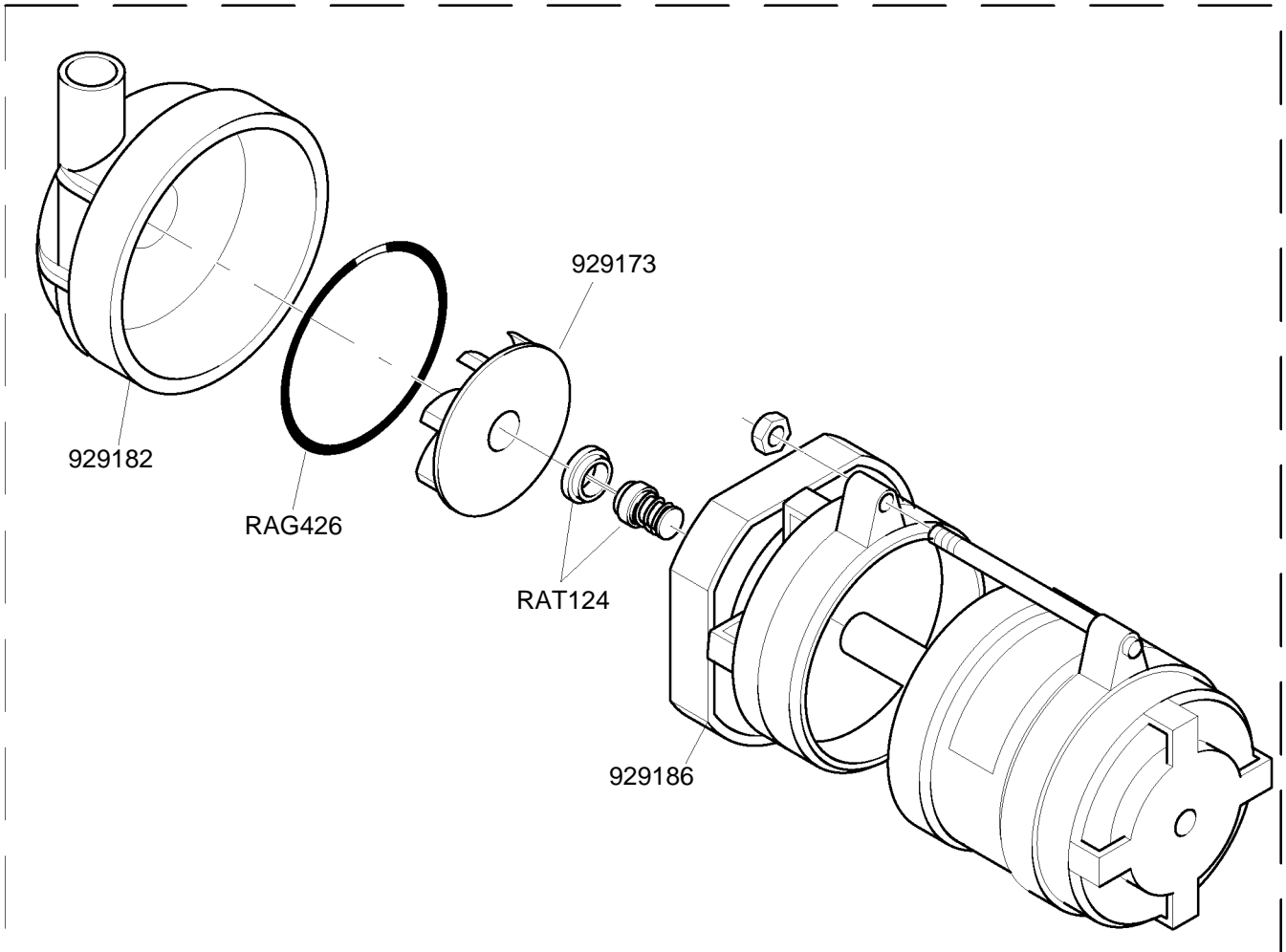

929167

CHH50 - CHH60 - CHH70 Drain Pump Assy

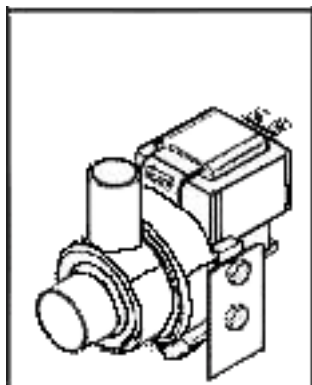

Drain Pump 220-240V 50Hz - 139321-1110

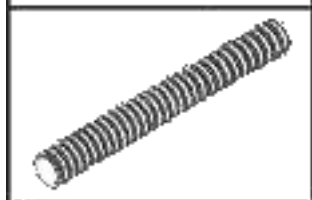

Drain Pipe 2000mm (drain pump to drain) DZS151 - 139321-968

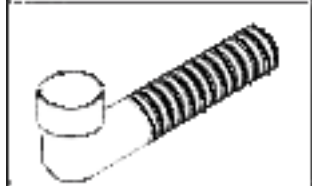

Drain Pipe (from machine to pump) 127056 - 139321-969

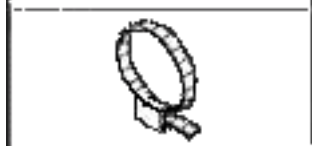

Jubilee Clip 40/60 -



Jubilee Clip 20/32 - 166513-6



Bolt 6MAx12 -

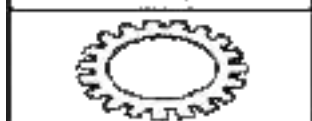

Lockwasher D6 - LWM-E-3-4

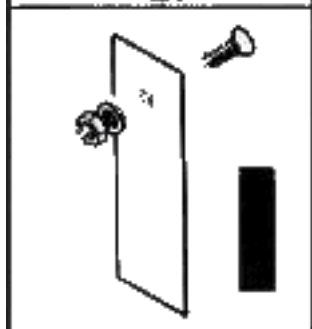

Timer Card (tally drain timer) -

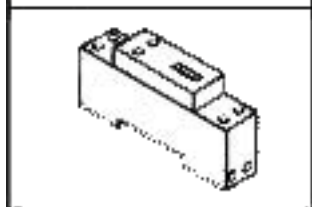

Timer (drain timer) -



As continued product improvement is a policy of HOBART, specifications are subject to change with-out notice.

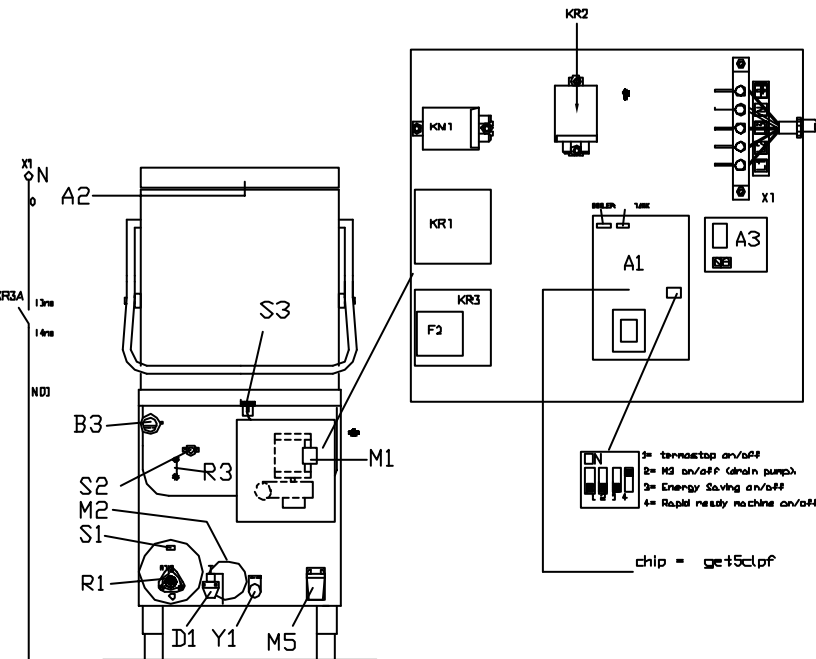
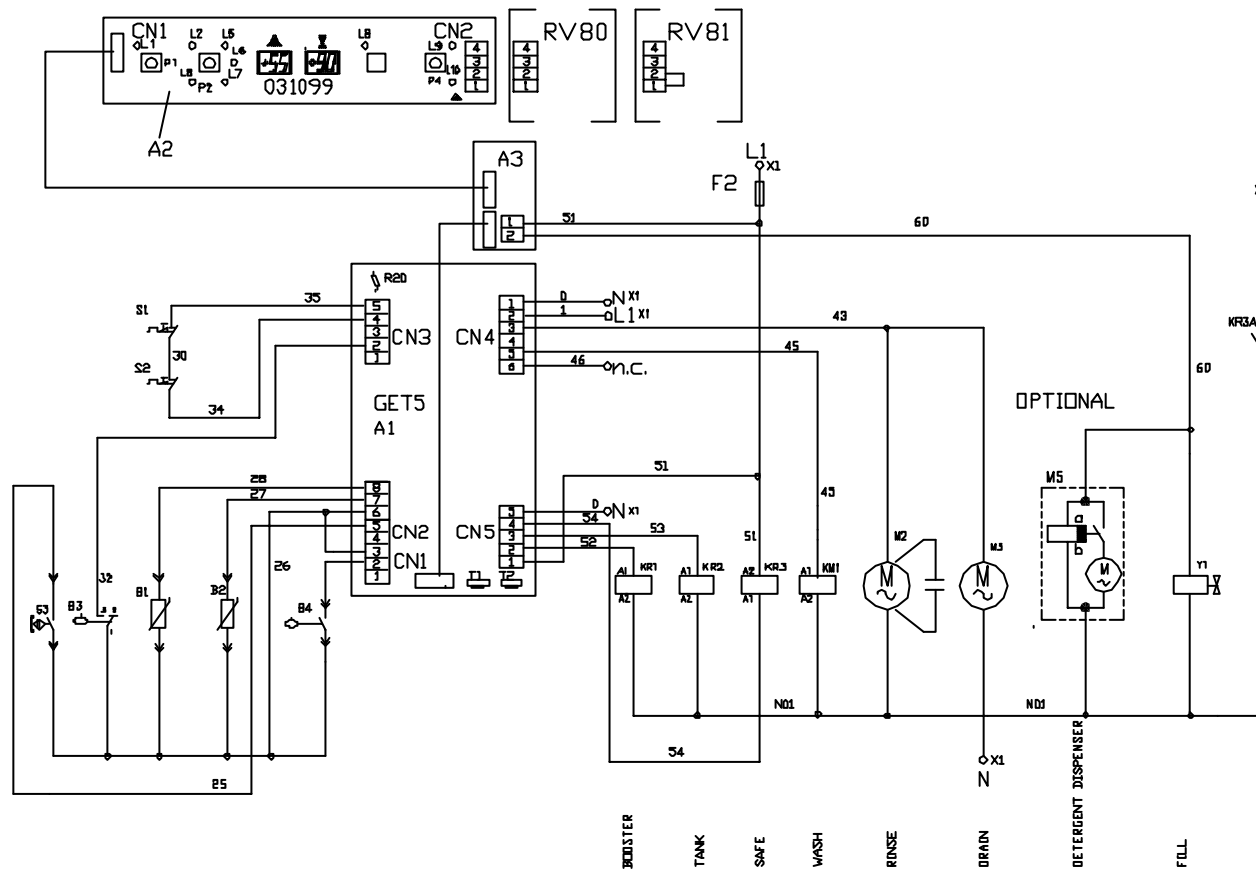
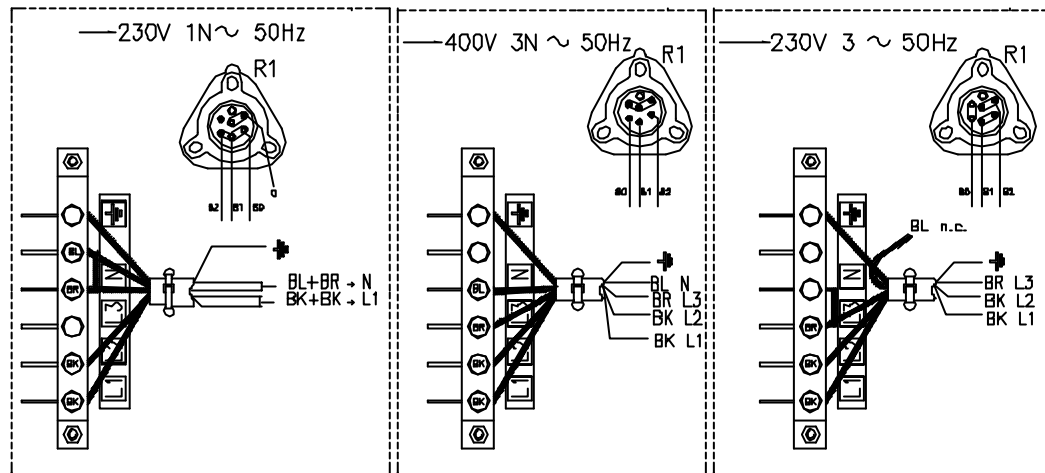
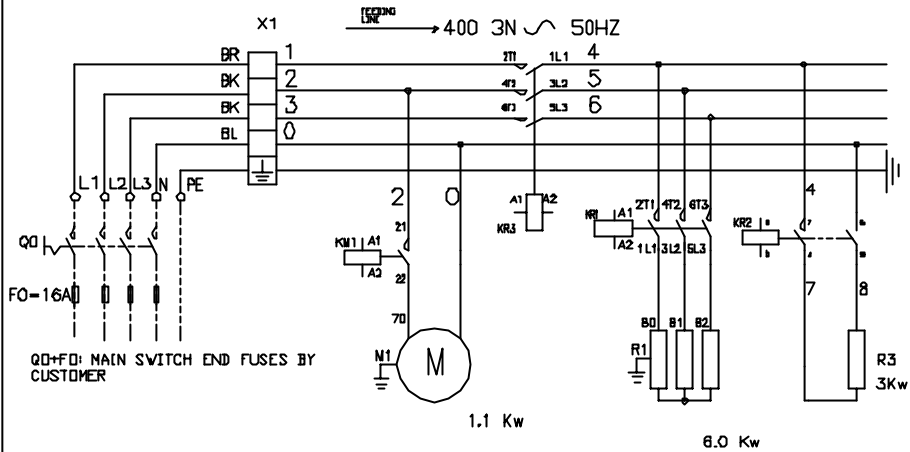

codice/code		RV80/RVB1		denominazione / denominazione	
disegnato / da re-examinato		data/date		SCHEMA ELETTRICO WIRING DIAGRAM	
10/12/02					
verificato / da/inspected by		data/date		disegno n°/file	
validato / da/validated by		data/date		81364	
		numero del/numero n° 81306-1		data/date 16/05/01	

SIMBOLO	DESCRIZIONI	DESCRIPTIONS	BESCHREIBUNGEN
A1/43	SCHEDA CONTROLLO ELETTRONICA ELECTRONIC CONTROL UNIT		FICHE DE CONTROLEELECTRONIQUE ELEKTRONISCHE BEDIENUNGSKARTE
A2	PANNELLO COMANDI CONTROL PANEL		TABEAU DE COMMANDES BEDIENUNGSPANEEL
B1	SONDA RESISTENZA VASCA PROBE TANK HEATER		THERMOSTAT RESISTENCE DE CUVE THANKHEIZUNG THERMOSTAT
B2	SONDA RESISTENZA BOILER BOOSTER HEATER THERMOSTAT		THERMOSTAT RESISTANCE BOYLER BOILERHEIZUNG -THERMOSTAT
B3	PRESSOSTATO LIVELLO VASCA TANK PRESSURE SWITCH		PRESSOSTAT NIVEAU CUVE DRUCKSCHALTER TANK-NIVEAUREGLER
B4	LIVELLOSTATO BOILER BOOSTER FLOAT SWICTH		INT. A ELOTEUR SCWINNERSCHALTER
F2	FUSIBILE COMANDI COMMAND FUSE		FUSIBLE SICHERUNGEN
F1	PROTEZIONE TERMICA ELETTRROPOMPA EL. WASH PUMP THERMAL PROTECTION		PROT. TERMIQUE MOTEUR EL. POMPE THERMISCHER MOTORPUMPESCHUTZ
KM1	TELERUTTORE ELETTRROPOMPA LAVAGGIO WASH ELECTROPUMP REMOTE-CONTROL		TELEREUPTEUR ELECTROPOMPE DE LAVAGE FERNSCHALTER DER WASCH-ELEKTROPUMPE
KR1	TELERUTTORE RESISTENZA BOILER BOOSTER HEATER REMOTE -CONTROL		TELERUPTEUR RESISTANCE SURCHAUFFEUR FERNSCHALTER DER BOILER -HEIZUNG
KR2	TELERUTTORE RESISTENZA VASCA RELAY FOR TANK HEATER ELEMENT.		RELAIS RESISTENCE DE CUVE NACHSPUELHEIZUNGSRELAIS.
KR3	TELERUTTORE SICUREZZA SAFETY HEATER REMOTE-CONTROL		TELERUPTEUR DE SECURITE SURCHAUFFEUR SICHERHEITS-FERNSCHALTER DES BOILERS
M1	ELETTRROPOMPA LAVAGGIO WASH MOTOR PUMP		ELECTROPOMPE LAVAGE WASCH-MOTORPUMPE
M2	ELETTRROPOMPA AUMENTO PRESSIONE RINSE BOOSTER PUMP		ELECROPOMPE SURPRESSEUSE DE RINCAGE DRUCKSTEIGERUNGSPUMPE
M5	MOTORE DOSATORE DETERSIVO RINSE AID DISPENSER MOTOR		MOTEUR DOSEUR TENSIOACTIF NACHSPÜLUNGSMITTELDOSIERGERÄT-MOTOR
P1	PULSANTE PARTENZA AUTOMATICA AUTOMATIC START PUSH BOTTON		INTERREPTEUR DEMARRAGE AUTOMATIC AUTOMATISCHER START WAEINSCALTER
P2	PULSANTE SELETTORE CICLO CYCLE COMMUTATOR		SELECTEUR CYCLE WAEHLSCHALTER FUER WASCHVORGANGSDAUER
P3	PULSANTE LINEA MAIN SWITCH		INTERRUPTEUR DE LIGNE NETZSCHALTER
R1	RESISTENZA BOILER BOOSTER HEATER HEATING ELEMENT		RESISTANCE SURCHAUFFEUR BOILERHEIZUNG
R3	RESISTENZA VASCA WASH TANK HEATING ELEMENT		RESISTANCE CUVE DE LAVAGE WASCHTANKHEIZUNG
S1	TERMOSTATO SICUREZZA BOILER SAFETY BOOSTER HEATER THERMOSTAT		THERMOSTAT DE SECURITE DU BOYLER BOILER -SICHERHEITS-THERMOSTAT
S2	TERMOSTATO SICUREZZA VASCA TANK SAFETY HEATER THERMOSTAT		THERMOSTAT SECURITE CUVE SICHERHEITS- TANKTHERMOSTAT
S3	MICROINTERRUPTORE MAGNETICO MAGNETIC MICROSWITCH		MICROINTERRUPTEUR MAGNETIQUE MAGNETISCHER MIKROSCHALTER
Y2	ELETTROVALVOLA RIEMPIMENTO BOILER BOILER FILLING ELECTRIC VALVE		ELECTROVALVE REMPLISSAGE SURCHAUFFEUR SOLENOIDVENTIL DER BOILERFÜLLUNG

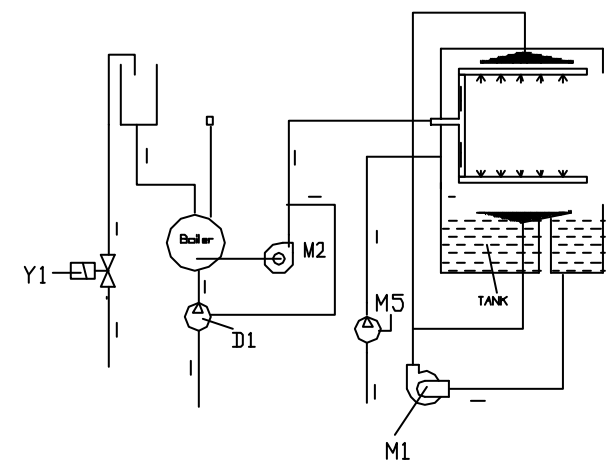
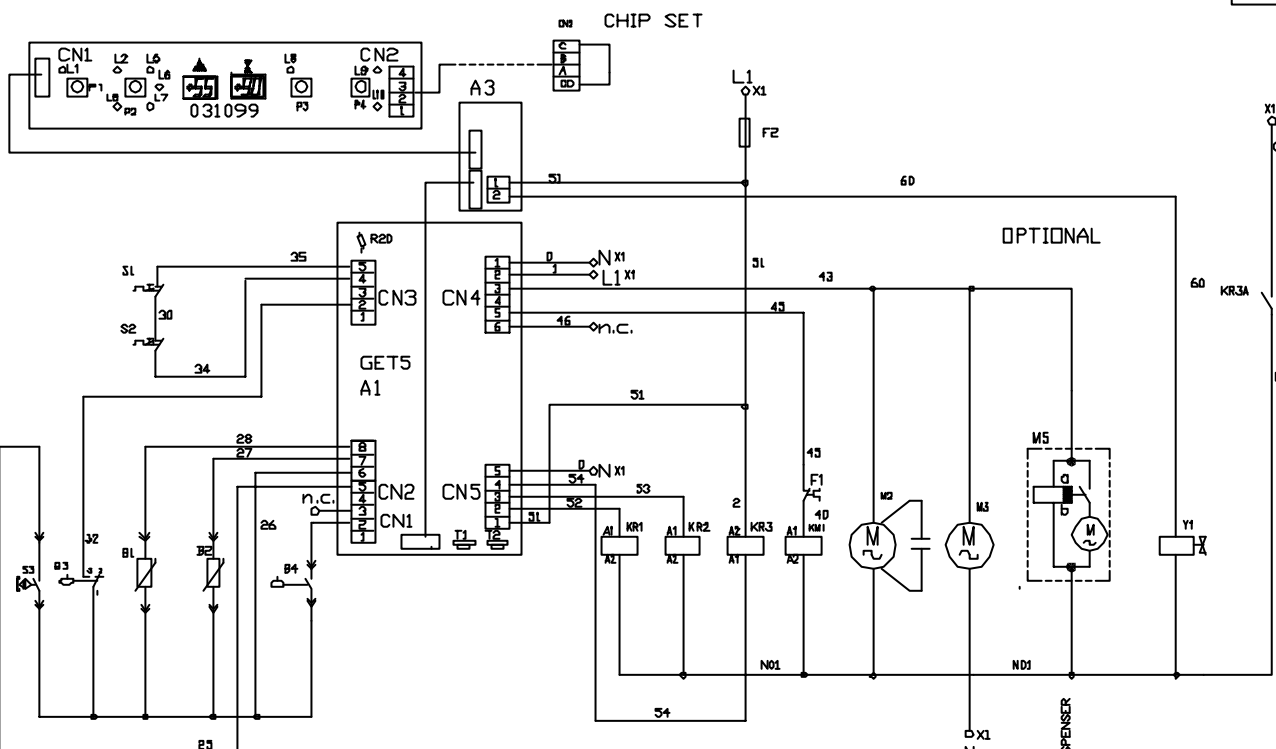
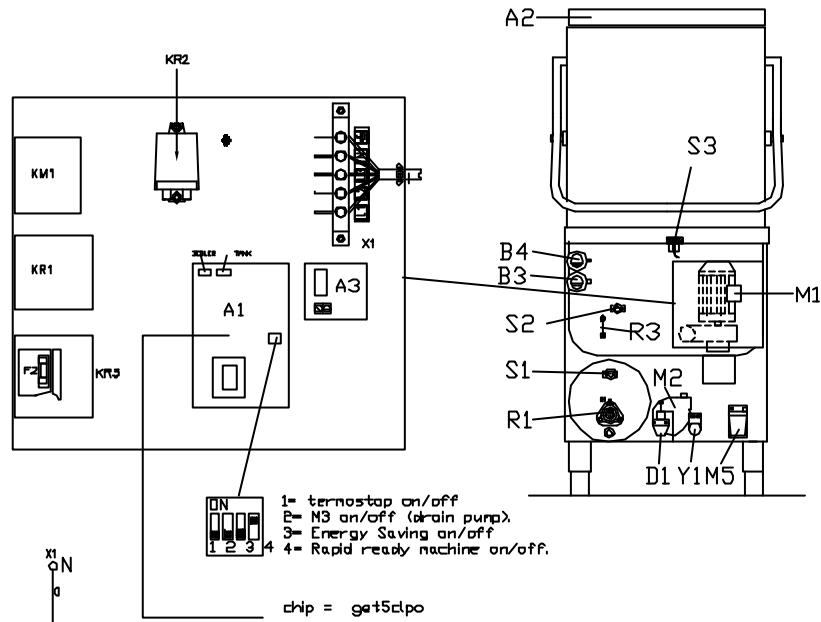
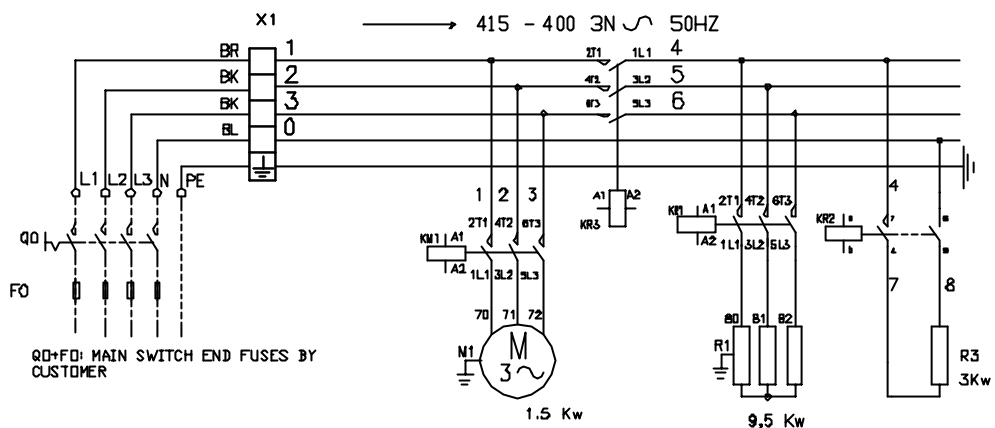

n° MODIFICA	DESCRIZIONE	SOSTITUISCE	DATA	destinazione/codice/code CWR82	denominazione / denominazione SCHEMA ELETTRICO WIRING DIAGRAMM	Codice 81350
				Dis. Riesaminato da re-examinat 04/11/02		
				verificato da/inspected by 04/11/02	descrizione apparecchiatura LAVASTOVIGLIE A CAPOT	disegno n°/file mod
				validato da/validated by 04/11/02	totale Fogli N°Foglio N°fog. successivo	81357 --

SIMBOLO	DESCRIZIONI	DESCRIPTIONS	BESCHREIBUNGEN
A1/43	SCHEDA CONTROLLO ELETTRONICA ELECTRONIC CONTROL UNIT		FICHE DE CONTROLEELECTRONIQUE ELEKTRONISCHE BEDIENUNGSKARTE
A2	PANNELLO COMANDI CONTROL PANEL		TABLEAU DE COMMANDES BEDIENUNGSPANEEL
B1	SONDA RESISTENZA VASCA PROBE TANK HEATER		THERMOSTAT RESISTENCE DE CUVE THANKHEIZUNG THERMOSTAT
B2	SONDA RESISTENZA BOILER BOOSTER HEATER THERMOSTAT		THERMOSTAT RESISTANCE BOYLER BOILERHEIZUNG -THERMOSTAT
B3	PRESSOSTATO LIVELLO VASCA TANK PRESSURE SWITCH		PRESSOSTAT NIVEAU CUVE DRUCKSCHALTER TANK-NIVEAUREGLER
B4	LIVELLOSTATO BOILER BOOSTER FLOAT SWICTH		INT. A ELOTEUR SCWINNERSCHALTER
F1	PROTEZIONE TERMICA ELETTRPOMPA EL. WASH PUMP THERMAL PROTECTION		PROT. TERMIQUE MOTEUR EL. POMPE THERMISCHER MOTORPUMPESCHUTZ
F2	FUSIBILE COMANDI COMMAND FUSE		FUSIBLE SICHERUNGEN
KM1	TELERUTTORE ELETTRPOMPA LAVAGGIO WASH ELECTROPUMP REMOTE-CONTROL		TELEREUPTEUR ELECTROPOMPE DE LAVAGE FERNSCHALTER DER WASCH-ELEKTROPUMPE
KR1	TELERUTTORE RESISTENZA BOILER BOOSTER HEATER REMOTE -CONTROL		TELERUPTEUR RESISTANCE SURCHAUFFEUR FERNSCHALTER DER BOILER-HEIZUNG
KR2	TELERUTTORE RESISTENZA VASCA RELAY FOR TANK HEATER ELEMENT.		RELAIS RESISTENCE DE CUVE NACHSPUELHEIZUNGSRELAIS.
KR3	TELERUTTORE SICUREZZA SAFETY HEATER REMOTE-CONTROL		TELERUPTEUR DE SECURITE SURCHAUFFEUR SICHERHEITS-FERNSCHALTER DES BOILERS
M1	ELETTRPOMPA LAVAGGIO WASH MOTOR PUMP		ELECTROPOMPE LAVAGE WASCH-MOTORPUMPE
M2	ELETTRPOMPA AUMENTO PRESSIONE RINSE BOOSTER PUMP		ELECROPOMPE SURPRESSEUSE DE RINCAGE DRUCKSTEIGERUNGSPUMPE
M5	MOTORE DOSATORE DETERSIVO RINSE AID DISPENSER MOTOR		MOTEUR DOSEUR TENSIOACTIF NACHSPÜLUNGSMITTELDOSIERGERÄT-MOTOR
P1	PULSANTE PARTENZA AUTOMATICA AUTOMATIC START PUSH BOTTON		INTERREPTEUR DEMARRAGE AUTOMATIC AUTOMATISCHER START WAEINSCALTER
P2	PULSANTE SELETTORE CICLO CYCLE COMMUTATOR		SELECTEUR CYCLE WAEHLSCHALTER FUER WASCHVORGANGSDAUER
P3	PULSANTE LINEA MAIN SWITCH		INTERRUPTEUR DE LIGNE NETZSCHALTER
R1	RESISTENZA BOILER BOOSTER HEATER HEATING ELEMENT		RESISTANCE SURCHAUFFEUR BOILERHEIZUNG
R3	RESISTENZA VASCA WASH TANK HEATING ELEMENT		RESISTANCE CUVE DE LAVAGE WASCHTANKHEIZUNG
S1	TERMOSTATO SICUREZZA BOILER SAFETY BOOSTER HEATER THERMOSTAT		THERMOSTAT DE SECURITE DU BOYLER BOILER-SICHERHEITS-THERMOSTAT
S2	TERMOSTATO SICUREZZA VASCA TANK SAFETY HEATER THERMOSTAT		THERMOSTAT SECURITE CUVE SICHERHEITS- TANKTHERMOSTAT
S3	MICROINTERRUPTORE MAGNETICO MAGNETIC MICROSWITCH		MICROINTERRUPTEUR MAGNETIQUE MAGNETISCHER MIKROSCHALTER
Y2	ELETTRVALVOLA RIEMPIMENTO BOILER BOILER FILLING ELECTRIC VALVE		ELECTROVALVE REMPLISSAGE SURCHAUFFEUR SOLENOIDVENTIL DER BOILERFÜLLUNG

CHH50 (electrical configuration data)

Single phase configuration 6 kW

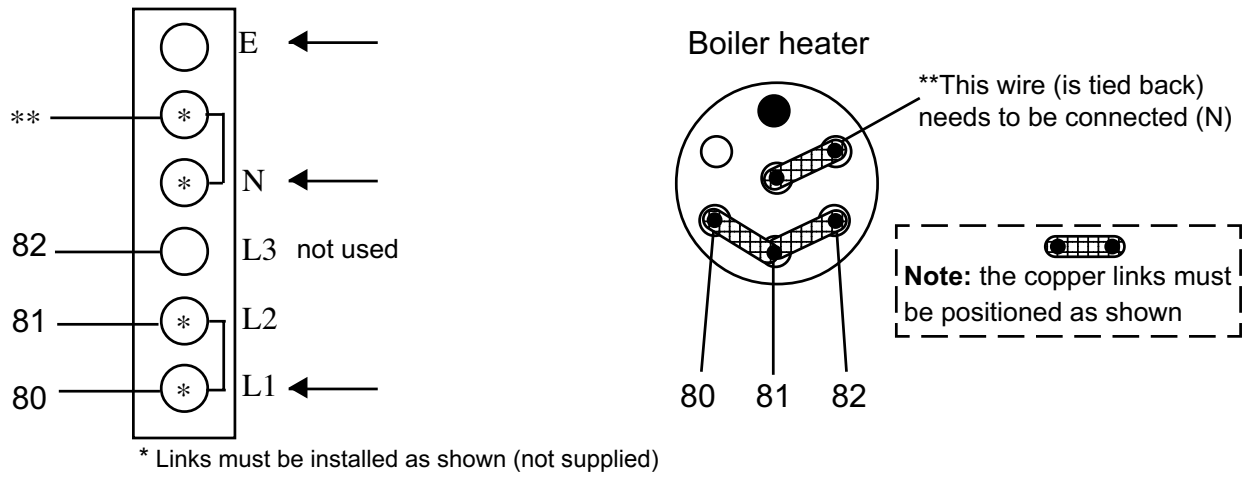

Three phase configuration 9 kW

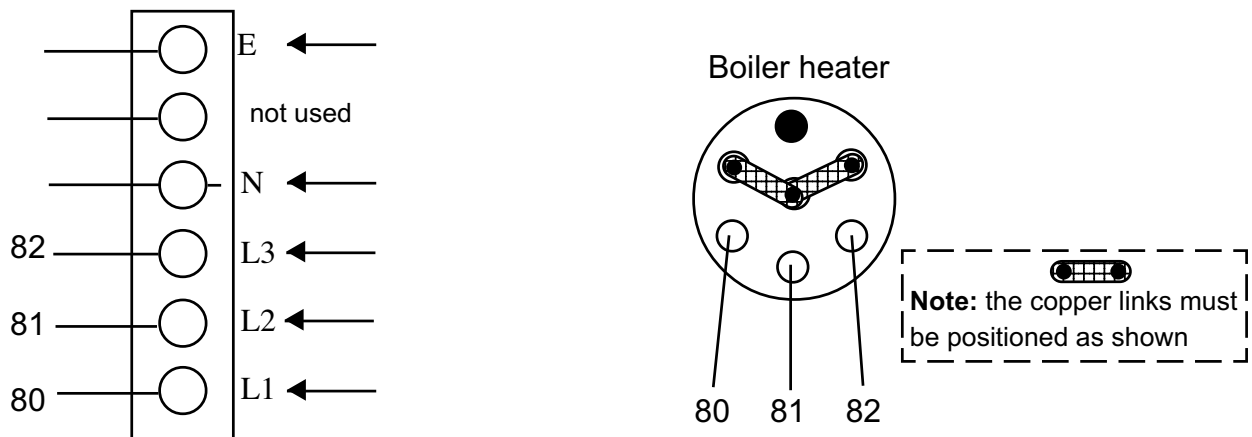

Bit switch settings

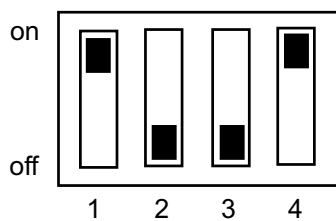

- 1 = Temperature check - (waits for boiler)
- 2 = Drain pump (option)
- 3 = Boiler standby - (holding temp 50°C)
- 4 = Boiler heating - (on or off)

DISHWASHER TECHNICAL SPECIFICATIONS

	EF40	EH60	EH70	EUT30	EUT60
Drain size	22MM	50MM	50MM	50MM	2"
Drain hose length	1,5M	1,80M	1,80M	1,80	No Hose
Water connection	3/4"	3/4"	3/4"	3/4"	3/4"
Water hose length	1,5M	2M	2M	2M	2M
Water pressure	1-4BAR	1-4BAR	1-4BAR	1-4BAR	1-4BAR
Water temp	15-55C	15-55C	15-55C	15-55C	15-55C
Total KW loading 3P	N/A	9.1KW	11.1KW	8.0KW	15.0KW
Total KW loading 1P	5,5KW/2,7KW	6.5KW	N/A	N/A	N/A
Mains cable length	3,0M	1,60M	1,60M	1,60M	1,60M
Mains cable size	3x4mm	5x2,5mm	5x4mm	5x2,5mm	5x4mm
Det pipe length	1,50M	1,50M	1,50M	N/A	N/A
R/aid pipe length	1,50M	1,50M	1,50M	N/A	N/A
Programme times. secs	60-120-180	60-110-150	50-85-110	120-240-360	120-240-360
Wat/consumption,cycle	3,3L	3L	2.7L	3.5L	8.0L
W/tank capacity	11L	20L	30L	40L	130L
R/tank capacity	6L	12L	12L	14L	14L
Drain pump	YES	NO	YES	NO	NO
W/pump rating	0,8KW	1.1KW	1.6KW	2.0KW	2X3KW
W/pump flow rate	260L/min	485L/min	534L/min	550L/min	950L/min
R/pump rating	0,45KW	0,15kw	0,15kw	0,15kw	0.45KW
R/pump flow rate	11L/min	36L/min	36L/min	36L/min	80L/min
Voltage 3P	N/A	400/50/3/N	400/50/3/N	400/50/3/N	400/50/3/N
Voltage 1P	230/50/1	230/50/1	N/A	N/A	N/A
Noise level(dB)	66db	66dB	67db	67db	69db
Rinse time	17 sec	15 sec	15 sec	17sec	17sec

DISHWASHER TECHNICAL SPECIFICATIONS

	CHG25	CHF40	CHH50	CLG25	CLF26
Drain size	20MM	22MM	50MM	18MM	22MM
Drain hose length	2,5M	1,5M	1,80M	1,5M	1,5M
Water connection	3/4"	3/4"	3/4"	3/4"	3/4"
Water hose length	1,5M	1,5M	2M	1,5M	1,5mt
Water pressure	1-4BAR	1-4BAR	1-4BAR	1-4BAR	1-4BAR
Water temp	50-55C	15-55C	15-55C	50-55C	50-55C
Total KW loading 3P	N/A	N/A	6.8KW	N/A	N/A
Total KW loading 1P	2,85KW	2,7KW/6,7KW	4.8KW	2,85KW	2,7KW/6,7KW
Mains cable length	3,0M	3,0M	1,60M	3,0M	3,0M
Mains cable size	3x1,5mm	3x4mm	5x2,5mm	3x1,5mm	3x4mm
Det pipe length	N/A	1,50M	1,50M	1,50M	
R/aid pipe length	1,50M	1,50M	1,50M	1,50M	1,50M
Programme times. secs	150	60-120-180	60-120-180	150	60-180
Wat/consumption,cycle	2,6L	3,3L	3L	2,6L	3.3L
W/tank capacity	11L	33L	20L	11L	33L
R/tank capacity	2.6L	6L	12L	2.6L	6L
Drain pump	YES	YES	NO	NO	YES
W/pump rating	0.15kw	0.8KW	0.8KW	0.15KW	0.8KW
W/pump flow rate	105L/min	330L/min	380lt/min	105L/min	330L/min
R/pump rating	0,45KW	0,45KW	0,15kw	0,45KW	0,45KW
R/pump flow rate	11L/min	11L/min	36L/min	11L/min	11L/min
Voltage 3P	N/A	N/A	400/50/3/N	N/A	N/A
Voltage 1P	230/50/1	230/50/1	230/50/1	230/50/1	230/50/1
Noise level(dB)	63db	67db	66dB	63db	67db
Rinse time	15 sec	17 sec	15 sec	17 sec	17 sec

ecomax

by **HOBART**

HOBART

INDEPENDENT

Hobart Independent
Southgate Way, Orton Southgate, Peterborough PE2 6GN

Tel: 0870 1688881
Fax: 01733 361347
E-mail: indsales@hobartindependent.com
Website: www.hobartindependent.com

As continued product improvement is a policy of HOBART / HOBART INDEPENDENT,
specifications are subject to change without notice.